



*User's Manual*

# *æro 50*



Antes de utilizar el equipo, lea la sección "Precauciones de seguridad" de este manual. Conserve este manual para futuras consultas.

Before operating the device, please read the "Safety precautions" section of this manual. Retain this manual for future reference.





### Caja acústica pasiva / Passive loudspeaker enclosure

El signo de exclamación dentro de un triángulo indica la existencia de importantes instrucciones de operación y mantenimiento en la documentación que acompaña al producto. Conserve y lea todas estas instrucciones. Siga las advertencias.



The exclamation point inside an equilateral triangle is intended to alert the users to the presence of important operating and maintenance (servicing) instructions in the literature accompanying the product. Heed all warnings. Follow all instructions. Keep these instructions.

El doble cuadrado indica equipo de Clase II.



The double square indicates Class II device.

Las especificaciones se encuentran en la etiqueta de la parte posterior del producto.

The specifications can be found on the rear label of the product.

No exponga este equipo a la lluvia o humedad. No use este aparato cerca del agua (piscinas y fuentes, por ejemplo). No exponga el equipo a salpicaduras ni coloque sobre él objetos que contengan líquidos, tales como vasos y botellas.

Do not expose this device to rain or moisture. Do not use this apparatus near water (for example, swimming pools and fountains). Do not place any objects containing liquids, such as bottles or glasses, on the top of the unit. Do not splash liquids on the unit.

Este símbolo indica que el presente producto no puede ser tratado como residuo doméstico normal, sino que debe entregarse en el correspondiente punto de recogida de equipos eléctricos y electrónicos.



This symbol on the product indicates that this product should not be treated as household waste. Instead it shall be handed over to the applicable collection point for the recycling of electrical and electronic equipment.

Equipo diseñado para funcionar entre 15°C y 42°C con una humedad relativa máxima del 95%.

Working temperature ranges from 15°C to 42°C with a relative humidity of 95%.

El cableado exterior conectado al equipo requiere de su instalación por una persona instruida o el uso de cables flexibles ya preparados.

The outer wiring connected to the device requires installation by an instructed person or the use of flexible cable already prepared.

El equipo cuenta con dos conectores de entrada en paralelo para facilitar la conexión de varias cajas en paralelo.

Note that the two Speakon input connectors are wired in parallel to provide easy parallel connection of several enclosures.

No emplace altavoces en proximidad a equipos sensibles a campos magnéticos, tales como monitores de televisión o material magnético de almacenamiento de datos.



Do not place loudspeakers in proximity to devices sensitive to magnetic fields such as television monitors or data storage magnetic material.

El colgado del equipo sólo debe realizarse utilizando los herrajes de colgado recomendados y por personal cualificado. No cuelgue la caja de las asas.

The appliance should be flown only from the rigging points and by qualified personnel. Do not suspend the box from the handles.

No existen partes ajustables por el usuario en el interior de este equipo. Cualquier operación de mantenimiento o reparación debe ser realizada por personal cualificado. Es necesario el servicio técnico cuando el equipo se haya dañado de alguna forma, como que haya caído líquido o algún objeto en el interior del aparato, haya sido expuesto a lluvia o humedad, no funcione correctamente, haya recibido un golpe o su cable de red esté dañado.

No user serviceable parts inside. Refer all servicing to qualified service personnel. Servicing is required when the apparatus has been damaged in any way, such as power-supply cord or plug is damaged, liquid has been spilled or objects have fallen into the apparatus, the apparatus has been exposed to rain or moisture, does not operate normally or has been dropped.

Limpie con un paño seco. No use limpiadores con disolventes.

Clean only with a dry cloth. Do not use any solvent based cleaners.



## DECLARACIÓN DE CONFORMIDAD DECLARATION OF CONFORMITY

### **D.A.S. Audio, S.A.**

C/ Islas Baleares, 24 - 46988 - Pol. Fuente del Jarro - Valencia. España (Spain).

Declara que *aero 50*:

Declares that *aero 50*:

Cumple con los objetivos esenciales de las Directivas:

Abide by essential objectives relating Directives:

- Directiva de Baja Tensión (Low Voltage Directive) 2006/95/CE
- Directiva de Compatibilidad Electromagnética (EMC) 2004/108/CE
- Directiva RoHS 2002/95/CE
- Directiva RAEE (WEEE) 2002/96/CE

Y es conforme a las siguientes Normas Armonizadas Europeas:

In accordance with Harmonized European Norms:

- EN 60065:2002 Audio, video and similar electronic apparatus. Safety requirements.
- EN 55103-1:1996 Electromagnetic compatibility. Product family standard for audio, video, audio-visual and entertainment lighting control apparatus for professional use. Part 1:Emission.
- EN 55103-2:1996 Electromagnetic compatibility. Product family standard for audio, video, audio-visual and entertainment lighting control apparatus for professional use. Part 2:Immunity.

## **GARANTÍA**

Todos nuestros productos están garantizados por un periodo de 24 meses desde la fecha de compra.

Las garantías sólo serán válidas si son por un defecto de fabricación y en ningún caso por un uso incorrecto del producto.

Las reparaciones en garantía pueden ser realizadas, exclusivamente, por el fabricante o el servicio de asistencia técnica autorizado.

Otros cargos como portes y seguros, son a cargo del comprador en todos los casos.

Para solicitar reparación en garantía es imprescindible que el producto no haya sido previamente manipulado e incluir una fotocopia de la factura de compra.

## **WARRANTY**

All D.A.S. products are warrantied against any manufacturing defect for a period of 2 years from date of purchase.

The warranty excludes damage from incorrect use of the product.

All warranty repairs must be exclusively undertaken by the factory or any of its authorised service centers.

To claim a warranty repair, do not open or intend to repair the product.

Return the damaged unit, at shippers risk and freight prepaid, to the nearest service center with a copy of the purchase invoice.

## CONTENTS

<b>SYSTEM DESCRIPTION</b>	<b>3</b>
<b>LINE DRAWINGS</b>	<b>3</b>
<b>RIGGING SYSTEM</b>	<b>4</b>
Warning	
Description	
<b>ASSAMBLING AN ARRAY</b>	<b>7</b>
<b>CONFIGURATIONS</b>	<b>12</b>
<b>SPECIFICATIONS</b>	<b>17</b>



## SYSTEM DESCRIPTION

The D.A.S. Audio *aero series*<sup>2</sup> offers units for applications requiring precise control of the vertical coverage and high sound pressure levels. The *aero 50* is an externally powered, three-way, high efficiency line array module which integrates two 15" low frequency units with 4" voice coils, four 8" mid-range devices which utilize 2.5" voice coils and two compression drivers with 3" coils and 1.5" exit geometry in a single unit. The compression drivers are coupled to two Serpis high frequency plane wave adaptors insuring coherent high frequency summing and the generation of a flat, isophasic wave front. When increased sound pressure level in the low frequency range is required, the system can be used in conjunction with the *LX-218C* (stacking) or the *LX-218CR* (rigging), subwoofer units (*LXseries* manual for more information).

These systems are ideal for applications such as large-scale outdoor/indoor events in arenas, stadiums or theaters. Use of the *DSP-4080* digital processor is recommended for the *aero series*<sup>2</sup> systems. Not using the *DSP-4080* digital processor with the *aero 50* will adversely affect the sound quality and may damage system components.

These units are manufactured using 15/18 mm Finnish Birch plywood. The *aero 50* enclosure shape is trapezoidal with 5° angles. The *LX-218C* and *LX-218CR* enclosures are rectangular. The *aero 50* system incorporates captive rigging hardware which is compatible with one another and designed to provide a fast, simple and safe rigging by means of quick release safety pins. Splay angles can be changed from 0° to 3.2° in 0.8° increments and from 3.2° to 9.6° in 1.6° increments.

To facilitate transport, the *aero 50* units are equipped with a *PL-50* front dolly panel attached by means of the rigging hardware. The front dolly panel is useful when rigging systems. The *LX-218CR* units can be moved by way of the *PL-LX218C* front dolly panel attached by means of the rigging hardware or by way of the *PL-218CS*, a dolly for vertically stacking (up to 3 units). The *LX-218C* units can be moved by way of the *PL-218CS*. Also an accessory, *KITW-100* (caster kit), is available.

The loudspeakers used in the system feature advanced technologies; new TAF (total air flow) cooling systems, Neodymium magnetic circuits which allow for important weight reductions, titanium diaphragms for the high frequency sections, and low-mid frequency cones manufactured using crossed fibers and elastic suspension that provide exceptional stability in the vertical plane.

The model *aero 50* includes two *15GNR*, 15" cone transducer with 4" EFW voice coils and Neodymium magnet assemblies in a bass-reflex configuration.

Four *8MN*, 8" speakers arranged on a V shape, incorporating 2.5" EFW voice coils, Neodymium magnet assemblies and TAF cooling system are used for mid-range reproduction. High frequencies are handled by two *M-75N* high frequency compression drivers with 3" EFW coil, Neodymium magnet and 1.5" exit coupled to twin *serpis*<sup>TM</sup> plane wave guide, designed by DAS Audio.

The *serpis*<sup>TM</sup> plane wave adaptor also serves as a heat sink for the compression driver.

## LINE DRAWINGS

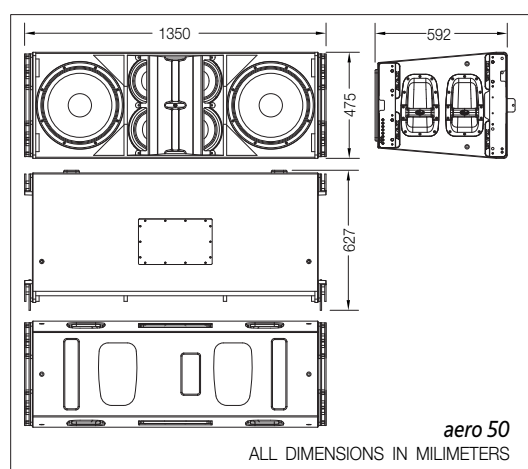



## RIGGING SYSTEM

### Warning

This manual contains needed information for flying DAS Audio line array systems, description of the elements and safety precautions. To perform any operations related to flying the system, read the present document first, and act on the warnings and advice given. The goal is to allow the user to become familiar with the mechanical elements required to fly the acoustic system, as well as the safety measures to be taken during set-up and teardown.

Only experienced installers with adequate knowledge of the equipment and local safety regulations should fly speaker boxes. It is the user's responsibility to ensure that the systems to be flown (including flying accessories) comply with state and local regulations.

The working load limits in this manual are the results of tests by independent laboratories. It is the user's responsibility to stay within safe limits. It is the user's responsibility to follow and comply with safety factors, resistance values, periodical supervisions and warnings given in this manual. Product improvement by means of research and development is ongoing at DAS Audio, specifications are subject to change without notice.

To this date, there is no international standard regarding the flying of acoustic systems. However, it is common practice to apply 5:1 safety factors for enclosures and static elements. For slings and elements exposed to material fatigue due to friction and load variation the following ratios must be met; 5:1 for steel cable slings, 4:1 for steel chain slings and 7:1 polyester slings. Thus, an element with a breaking load limit of 1000 kg may be statically loaded with 200 kg (5:1 safety factor) and dynamically loaded with 250 Kg (4:1 safety factor).

When flying a system, the working load must be lower than the resistance of each individual flying point in the enclosure, as well as each box. Rigging hardware should be regularly inspected and suspect units replaced if in doubt. This is important to avoid injury and absolutely no risks should be taken in this respect. It is highly recommended that you implement an inspection and maintenance program on flying elements, including reports to be filled out by the personnel that will carry out the inspections. Local regulations may exist that, in case of accident, may require you to present evidence of inspection reports and corrective actions after defects were found.

Absolutely no risks should be taken with regards to public safety. When flying enclosures from ceiling support structures, extreme care should be taken to assure the load bearing capabilities of the structures so that the installation is absolutely safe. Do not fly enclosures from unsafe structures. Consult a certified professional if needed. All flying accessories that are not supplied by DAS Audio are the user's responsibility. Use at your own risk.

### Description

DAS Audio *aero 50* and *LX-218CR*, line array systems, include 2 rigging structures on each side of the box. Manufactured from zinc plated steel they are painted black and are affixed to an internal plate with special crop resistant screws. Two special stainless steel guides are assembled to each of the structures: G1A50 (front guide) and G2A48 (back guide), allow for stacking or flying of boxes. Splay angles can be changed from 0° to 3.2° in 0.8° increments and from 3.2° to 9.6° in 1.6° increments. To lock both guides, six (6) quick release safety pins (supplied) must be used.

The G1A50 front guide provides a solid connection to the box and whatever is on top of it, while the G2A48 rear guide determines the vertical splay angle (whether stacked or flown), as a function of the hole where the pin gets inserted.

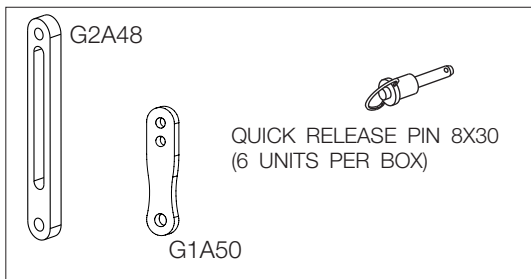

To aid the setting of the G2A48 guide in the corresponding hole in the top box, each hole is labeled with an associated angle, both for stacked and flown applications. To fit the guides into the holes, highly resistant 8 mm quick release pins with a ball safety lock are used.

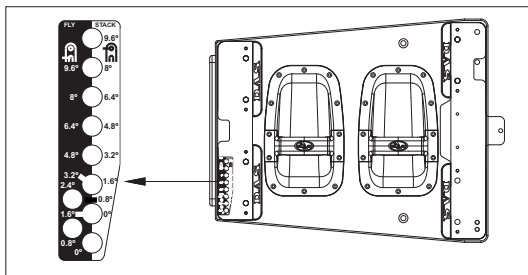

For flying boxes and defining the splay angle, the pins must be inserted in the slot of G2A48, whereas for stacking (stacked), the pin goes through the top hole of the guide.

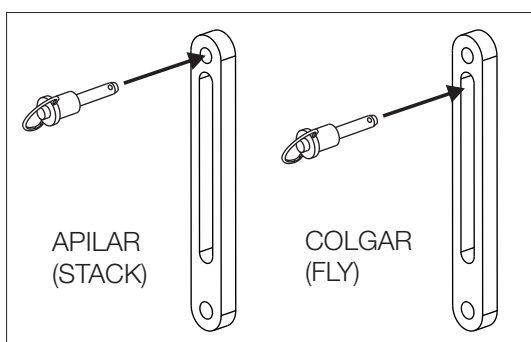

All of the elements needed to rig or stack the systems are integral to the enclosure (G1A50, G2A48 and the quick release safety pins). The additional items needed are the **AX-AERO50** rigging structure (bumper bar), chains and hoists, the **PL-50** dolly platforms and the **AX-COMBO12** rigging adapter.

#### A) **AX-AERO50**

The **AX-AERO50** rigging structure is made up of a central pick-up bar made of steel and two dismountable lateral panels that are attached to the pick-up bar by way of steel safety pins. There is an intermediate reinforcement which is used to attach the lifting cables. The position of the safety pins will determine the angle of the array (see the positions marked on the AX-AERO50).

The structure will be attached to the first enclosure of the array by means of the guides G1A50, G2A48, and six quick release safety pins.

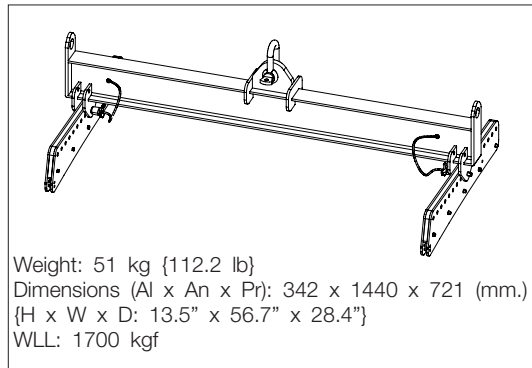

#### B) Chain hoists

All units in a column will be flown from the **AX-AERO50** rigging structure (bumper bar), which should be used with one hoist. The hoist should have an adequate load capacity. In case of flying 12 units or more, two hoists and two pick up bars will be needed.

#### C) Platform **PL-50**

The **PL-50** dolly panels facilitate transport of the **aero 50** systems. They can also be used to facilitate flying the systems. Each cover is attached to the enclosure by using the flying hardware attached to each box and is fixed with the quick release safety pins.

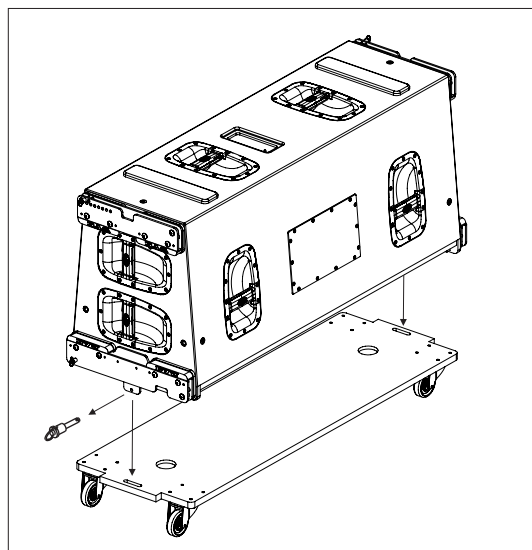

#### D) AX-COMBO12

The *AX-COMBO12* is a rigging adapter to be used when *aero 12A* units are needed to be flown under *aero 50* units as dowfill systems. Maximum 6 *aero 12A* units can be flown from this rigging grid. The *AX-COMBO12* includes front and rear steel guides which permit variation of the angle between it and the last *aero 50* cabinet in the cluster. Angles vary from 1.8° to 9.6°.

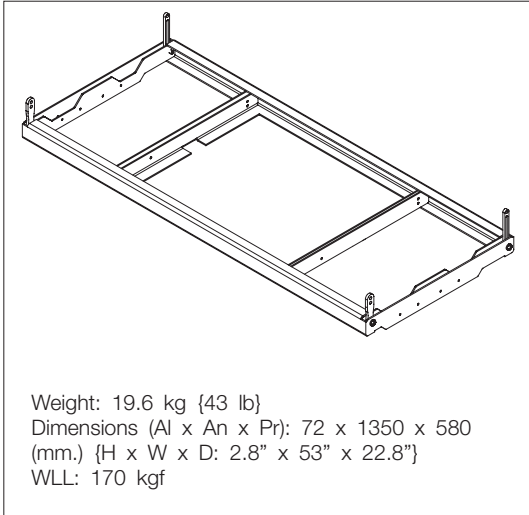

The *AX-COMBO12* is joined to the last *aero 50* cabinet using G1A50 and G2A48 included steel guides and 6 quick release pins. The angle depends on the hole of the rigging structures where the pins are inserted, through the slots of G2A48. The first *aero 12A* unit is joined to the *AX-COMBO12* using its G1A and G2A included steel guides and quick release pins.

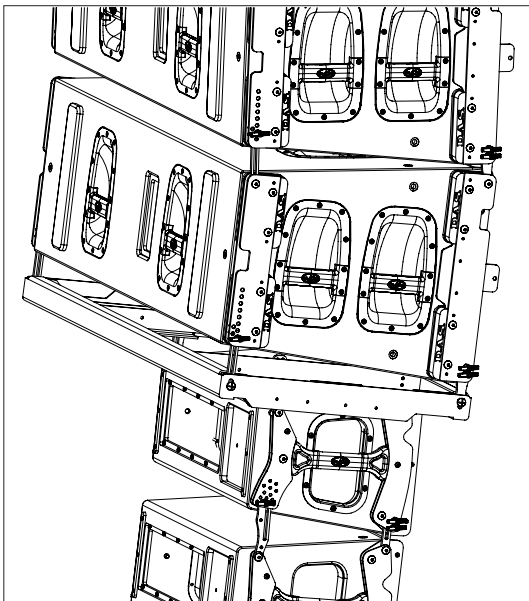

#### Safety factors

The safety factor is defined as the coefficient between the breaking load limit and the maximum safe working load limit (SWLL). In this case, the breaking load limit of each of the flying points is 4,000 kg (8,820 lbs) as determined by destructive testing in independent laboratories. With a 10:1 safety factor, a total amount of 1,600 kg (3,527 lbs) can be flown from the 4 flying points. Each flying point has a capacity of 400 kg (882 lbs) with a 10:1 safety factor.

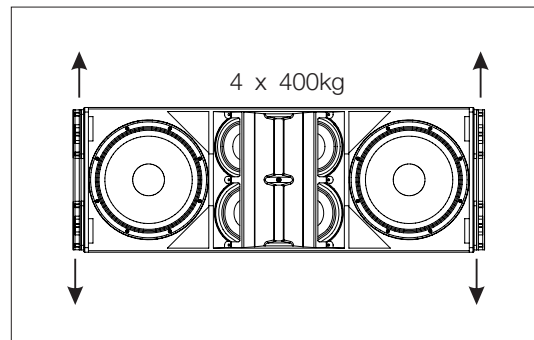

The maximum number of units that can be suspended from the *AX-AERO50* flying grid is 16. The maximum limits established by the manufacturer should never be exceeded.

The use of two hoists with a load capacity as expressed on the previous page is mandatory. It should be kept in mind that at certain moments, the complete load may be supported by only one of the hoists. This is why the load capacity of the individual hoist must be superior to the weight of the array column.

## ASSEMBLING AN ARRAY

### Transporting the cabinets

To facilitate transport, the *aero 50* units are equipped with a *PL-50* front dolly panel attached by means of the rigging hardware. The front dolly panel is useful when rigging systems. The *LX-218CR* units can be moved by way of the *PL-LX218C* front dolly panel attached by means of the rigging hardware or by way of the *PL-218CS*, a dolly for vertically stacking (up to 3 units). The *LX-218C* units can be moved by way of the *PL-218CS*. Also an accessory, *KITW-100* (caster kit), is available (*LX series* manual for more information).

### Planning/inspection

Before installing the system it is a good idea to run a simulation with the *Ease Focus* program utilizing the venue dimensions. This way we can determine the needs that should be met by the rigging structures such as hoists, cranes, beams, rigging points, etc. Besides providing weight information, the program also provides users with splay angle information, safety pin positions and coverage predictions.

It is extremely important to assure that each and every one of the aforementioned structures is capable of supporting a superior load than that of the complete system.

Inspection is the next step after planning and acquiring all the necessary parts needed to elevate the systems. All parts, including the hardware attached to the enclosure, the safety pins, etc. should be thoroughly inspected before each use. Units exhibiting deformations, cracks or any other defect should be replaced with new units.

It is important to establish an inspection routine for the complete rigging system before each event or installation as well as establishing the maximum load specifications of the hoists to be used.

Rigging should be carried out by experts familiar with the way the systems function and their characteristics.

On occasions, it may be convenient to have additional tie down points to impede the array from twisting or swinging.

### Assembling an array “one by one”

When few units are to be used (minimum systems recommended is 6 units) or when the dolly platforms cannot be used due to a lack of space, the enclosures will have to be hung “one by one”. The first step will be to attach the *AX-AERO50* grid structure to the hoists. The chain slings need to be attached to the structure using the shackles provided with the grid.

Once this is accomplished, the *AX-AERO50* structure is set in its vertical position, taking into consideration the position of the safety pins. Using the *Ease Focus* simulation software will provide the points that should be used for the required angle (see ‘1’ and ‘2’ below).

The next step is to attach the first unit to the *AX-AERO50* by introducing the G1A50 and G2A48 guides in the receiving points of the rigging structure and assuring them with the six safety pins. The safety pins should be inserted in the slot of the G2A48. It is very important to make sure that the pins have been inserted and locked correctly.

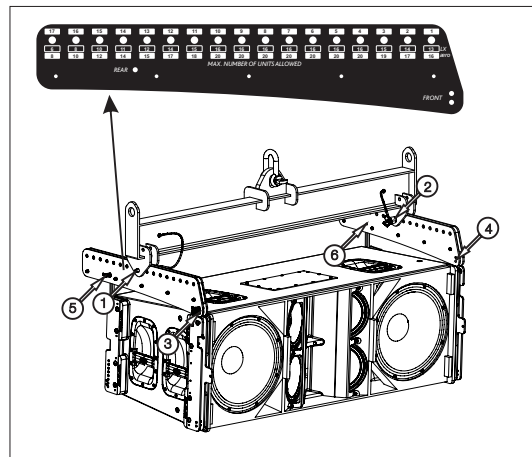

Once the first unit of the array has been attached to the *AX-AERO50*, the assembly should be lifted by way of the hoist until the wheels of the *PL-50* dolly platform lift off the ground. From this point on, the hoist can be used to lift the box into a horizontal position.

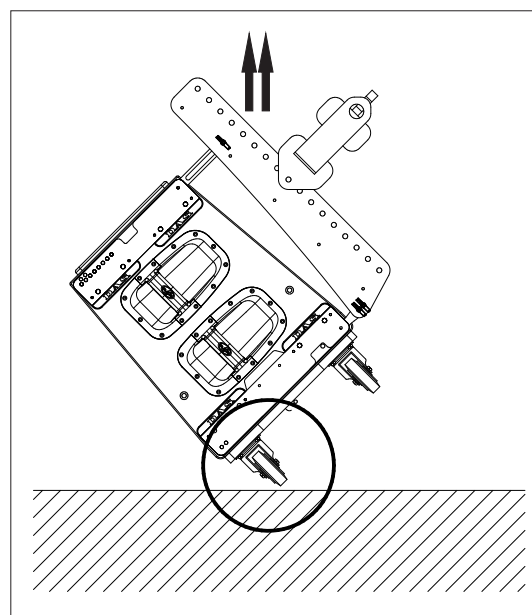

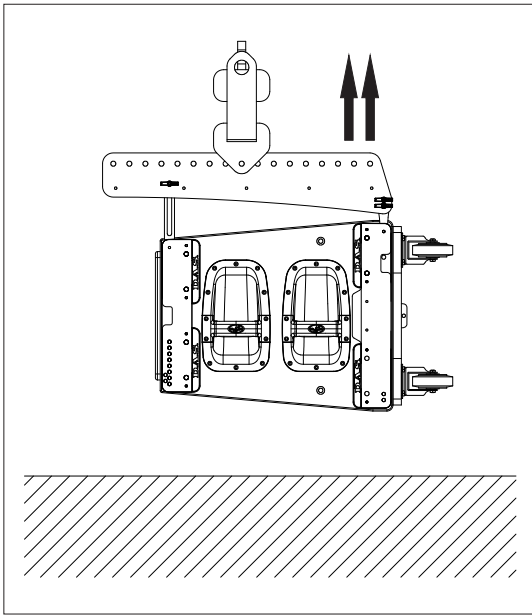

Once the first box has been placed at 0° and raised approximately 75cm (30 in) the second box of the array can be placed nearby. Once located in position, the G2A48 guides of the second box should be freed and inserted in the rear located receiving points of the suspended box and secured with the safety pins.

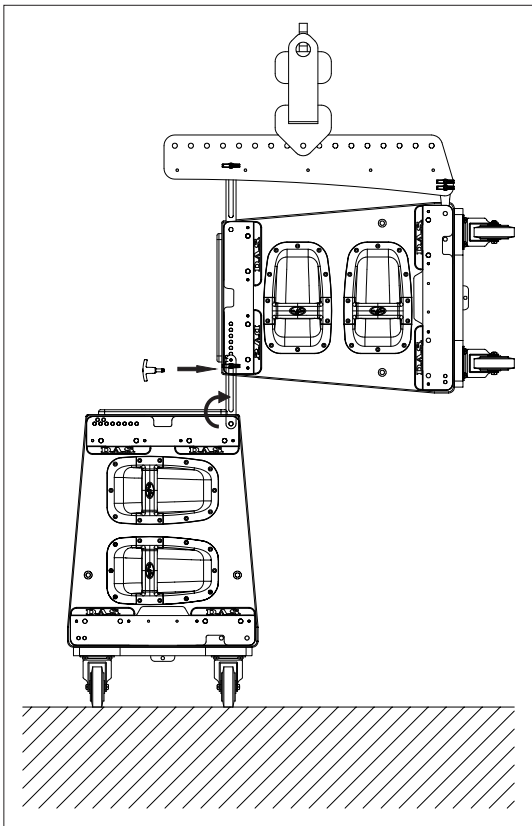
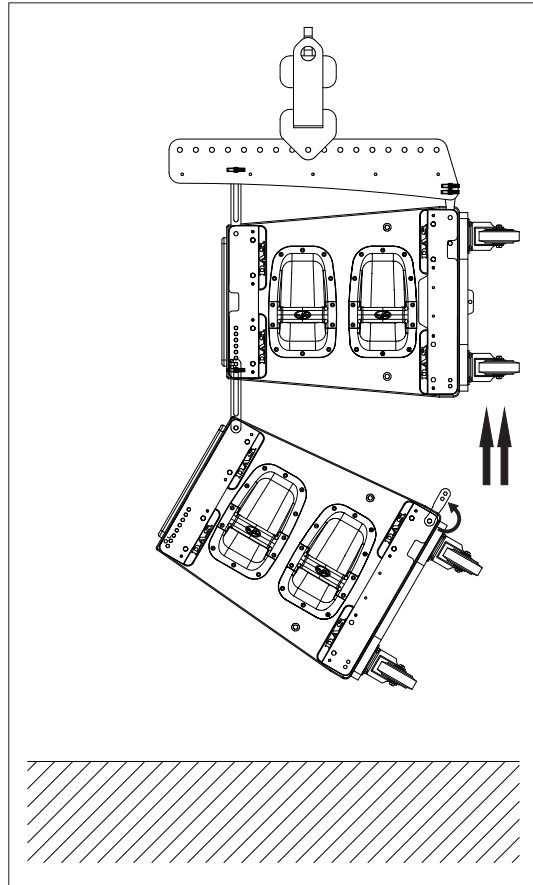

Once the splay angle between the first two boxes has been determined, the front of the box can be lifted into place. Three people will be needed to undertake this operation, two to lift the box and one to fit the G1A50 guide and safety pins into the upper box.

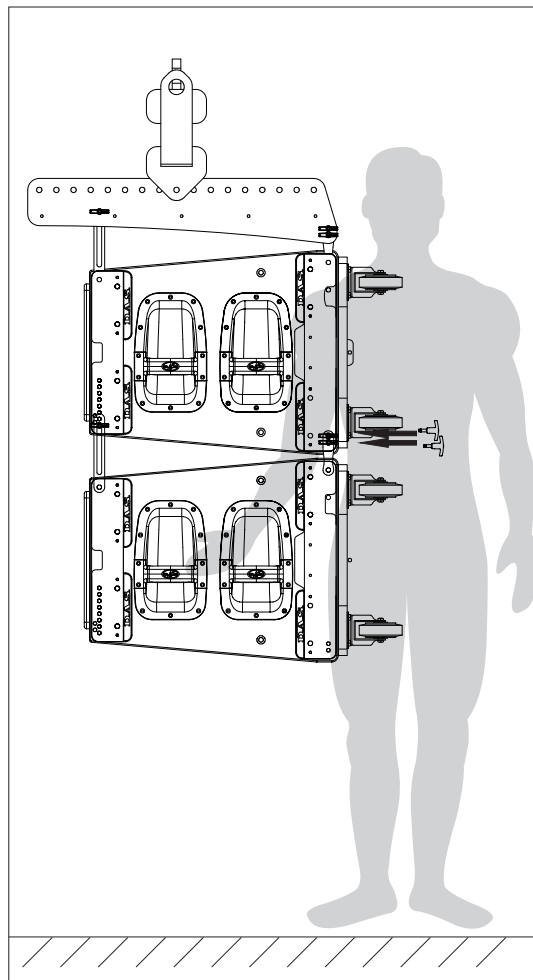

Once the boxes have been joined, the front dolly panels can be removed. The next boxes should be attached “one by one” using the methods described. Finally, the array should be hoisted to the correct height and secured with slings to avoid swinging.

This method is more time consuming than assembling an array by the “all at once” procedure, but is appropriate for situations due to a lack of space in which to array the system. During the process, the safety pins should be checked making sure they are secured correctly. Once the complete array has been lifted into place, additional slings should be attached to secure the array and avoid swinging.

### Assembling an array using the PL-50 platform

The PL-50 platform can be used to easily transport *aero 50* units to the assembling area. To use this method of assembling and hoisting the array, there must be enough space to permit linking all the boxes from the front of the rigging hardware.

The first step will be to attach the AX-AERO50 grid and the hoist (or hoists). Once this has been accomplished, the rigging structure can be placed in a vertical position by lifting the rear hoist and lowering the front hoist so that the rear of the grid is on top and the front of the grid at the bottom, ready to receive the first box.

The next step is to attach the first unit to the grid by introducing the G1A50 and G2A48 guides in the receiving points of the grid structure and assuring them with the (6) safety pins. The safety pins should be inserted in the slot of the G2A48. It is very important to make sure that the pins have been inserted and locked correctly.

Once the first box is attached to the structure, the remaining boxes should be brought to the array and attached repeating the previous steps (1 and 2) using G1A50 guides and safety pins per side making sure that the pins have been inserted and locked correctly.

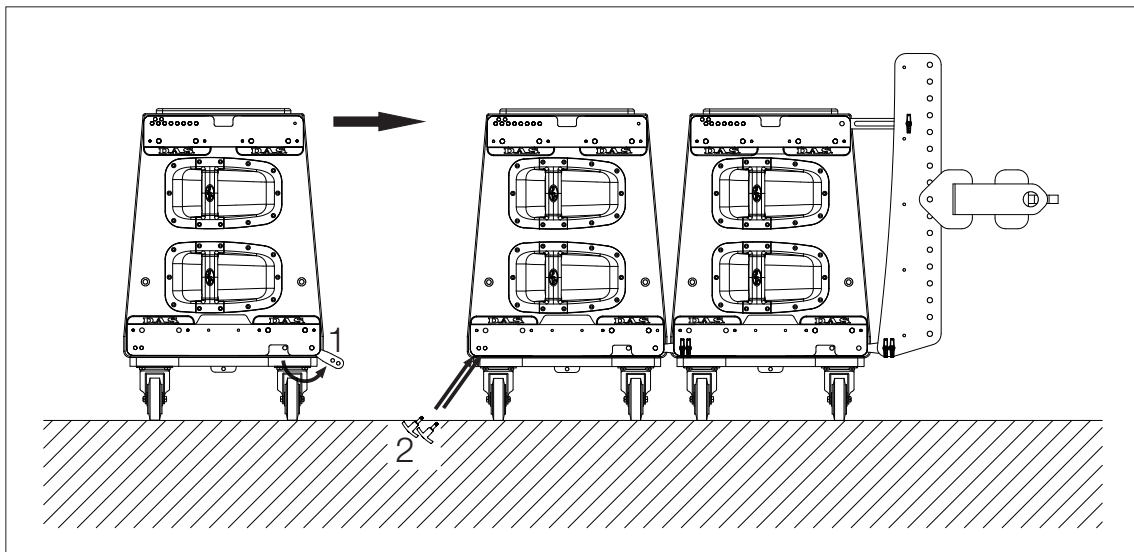
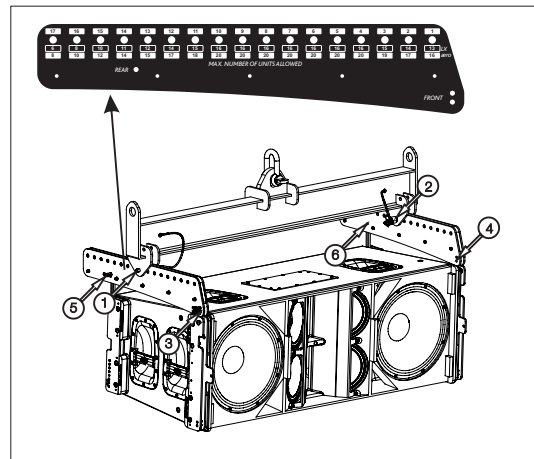

Proceed to attach the remaining units in the same manner until all the array units are attached to one another. For example, if we are assembling a six unit array, the process will be repeated six times. When all the units are attached, the complete array is ready to be hoisted.

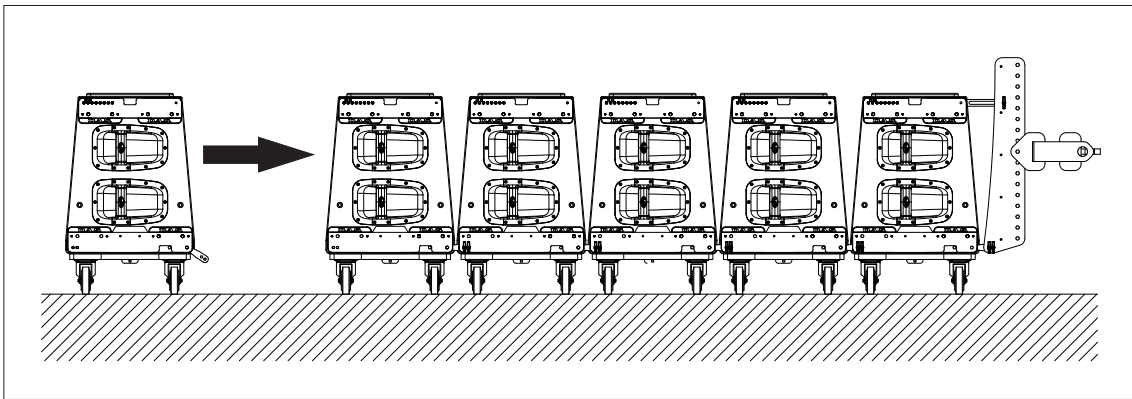

The complete assembly should begin being lifted from the hoist (3) so that the rear of the enclosures come together due to their trapezoidal shape. The hoist will be used only to take up slack in the chain, all the weight should be on the hoist. Proceed in this manner until the wheels of the last enclosure are off the ground. From here on, the array can now be lifted with the hoist.

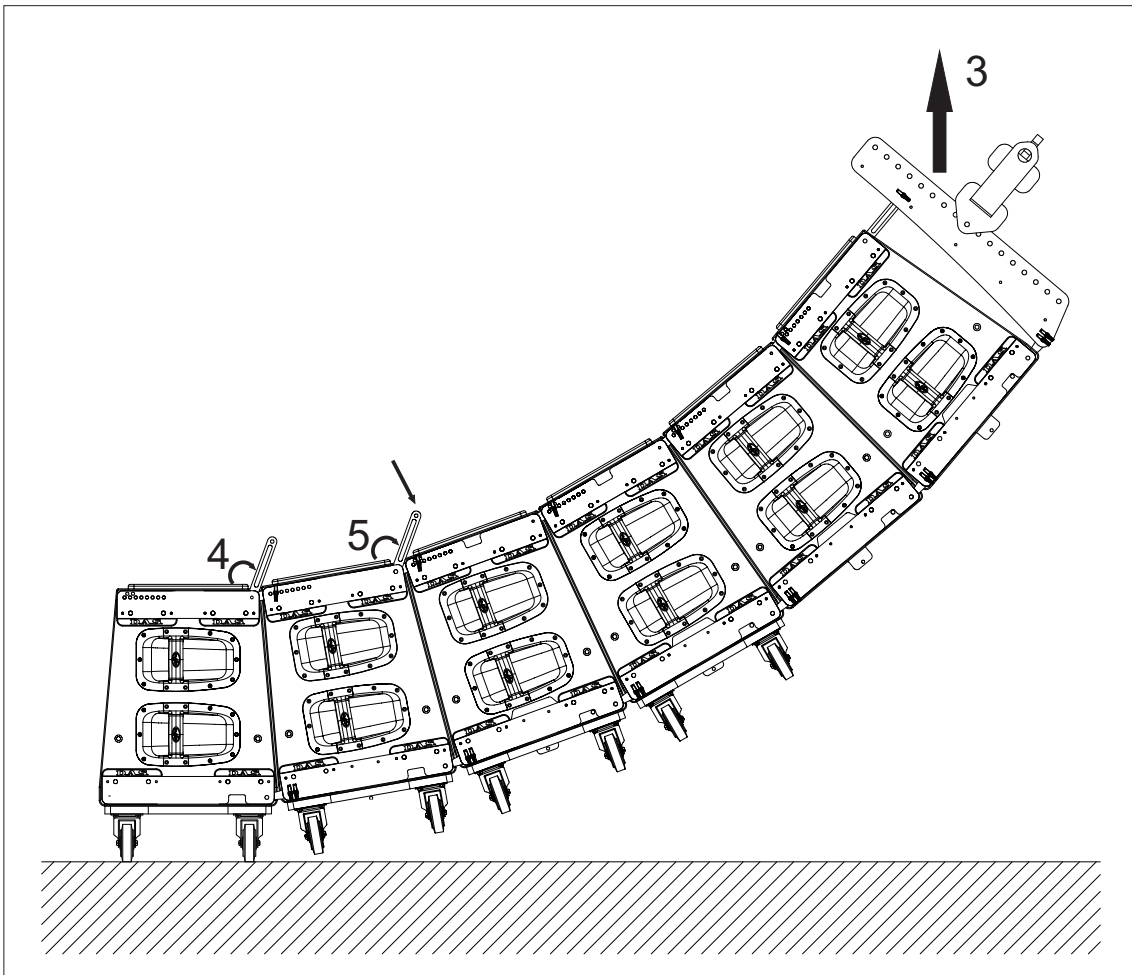

When the rear of the enclosures come together, the G2A48 rear guides should be positioned (4) into the hardware of the box above, inserting (5) the safety pins in the correct angle position. Since the boxes are flown, the safety pins should be in the slot of the G2A48 guide.

As the array assembly is lifted (6 & 7), the *PL-50* platforms should be removed.

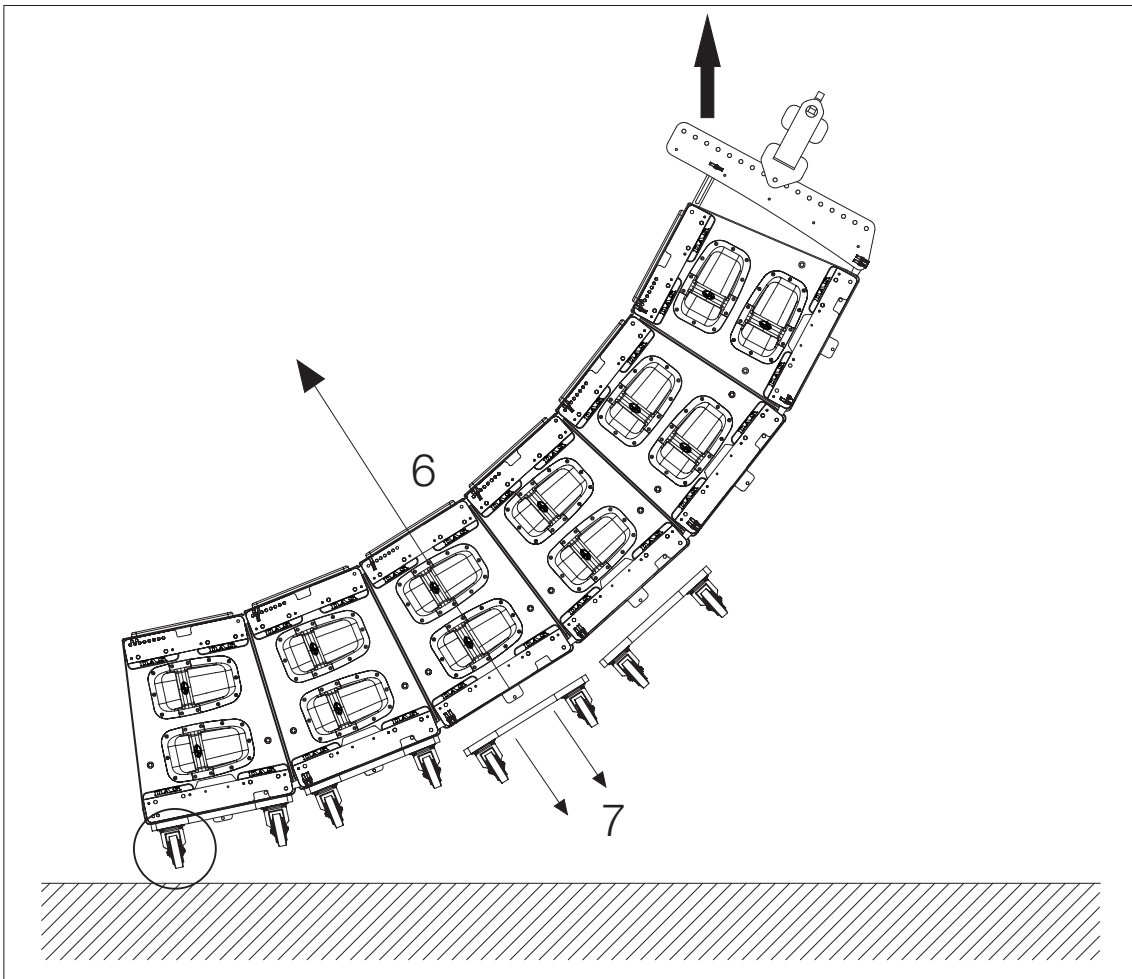

Once the complete array has been lifted into place, additional slings should be attached to secure the array and avoid swinging.

To lower the system, both hoists should be used until the lowest box is about 1 meter from the ground. From there on, only the front hoist should be used so that the array assembly begins to lean forward, at the same time, the *PL-50* platforms should be reattached. When the wheels of the lowest enclosure are firmly on the ground, the array assembly can now be lowered using the rear hoist.

While the array assembly descends, the rear of the enclosures will come together, at that moment, the safety pins which hold the G2A48 guides in place should be removed. Once removed, the guides should be swung back into the box they belong to. Finally, the boxes should be totally detached from one another by releasing the G1A50 guide.



**CONFIGURATIONS**

16 x aero 50  
16 x LX-218C  
Subs: left & right

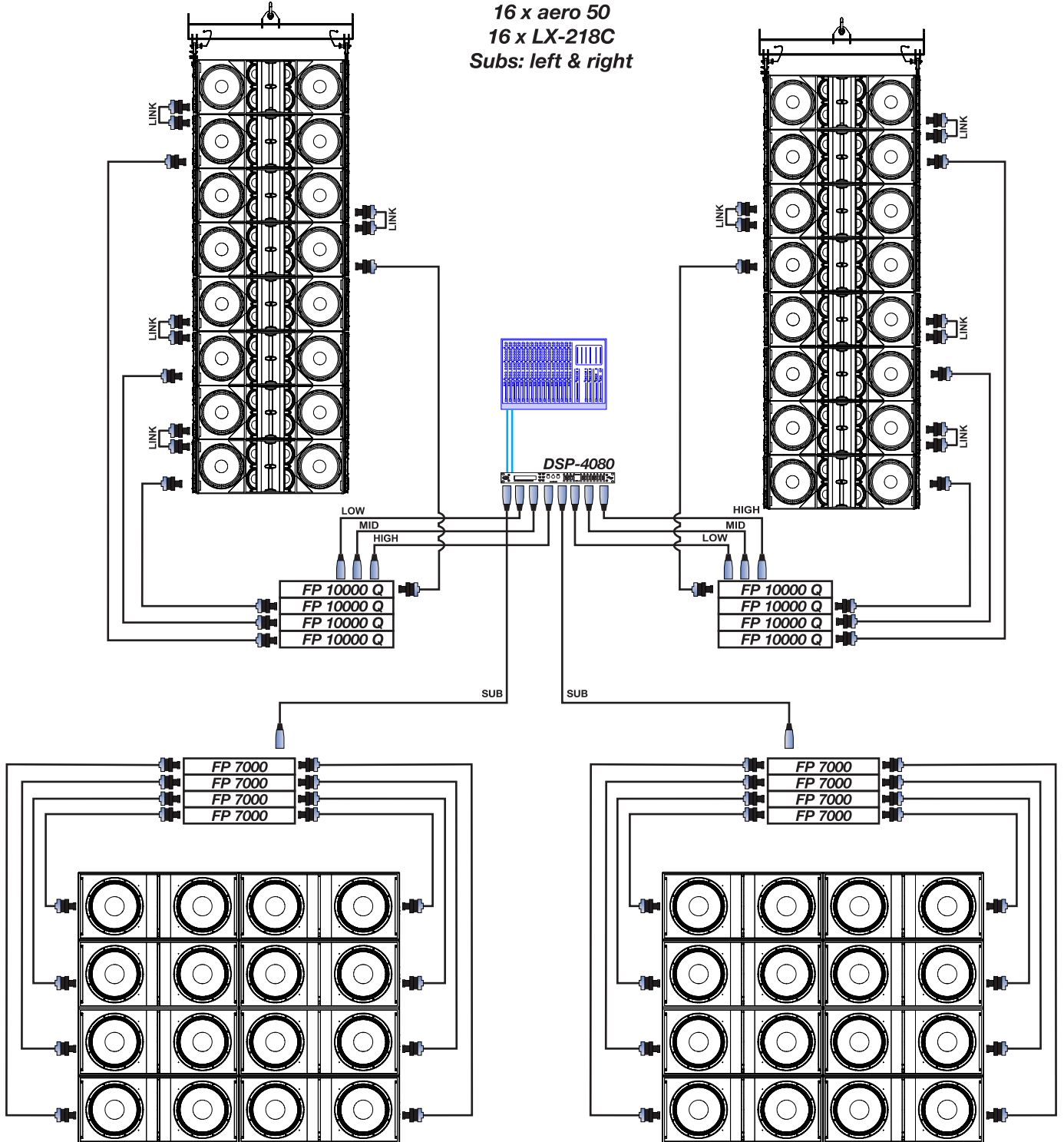

16 x aero 50  
24 x LX-218CA  
Center Cardiod Subs

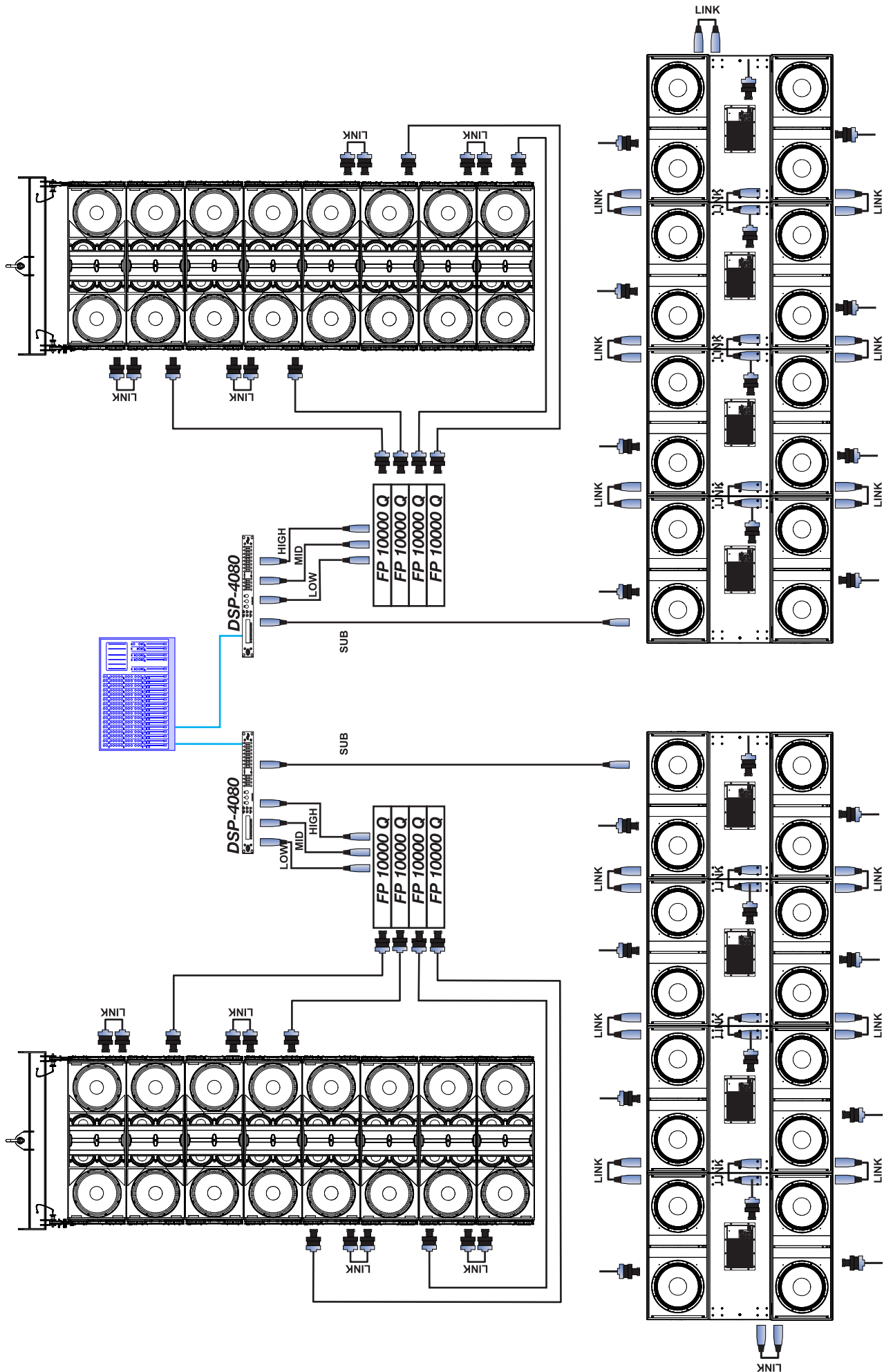

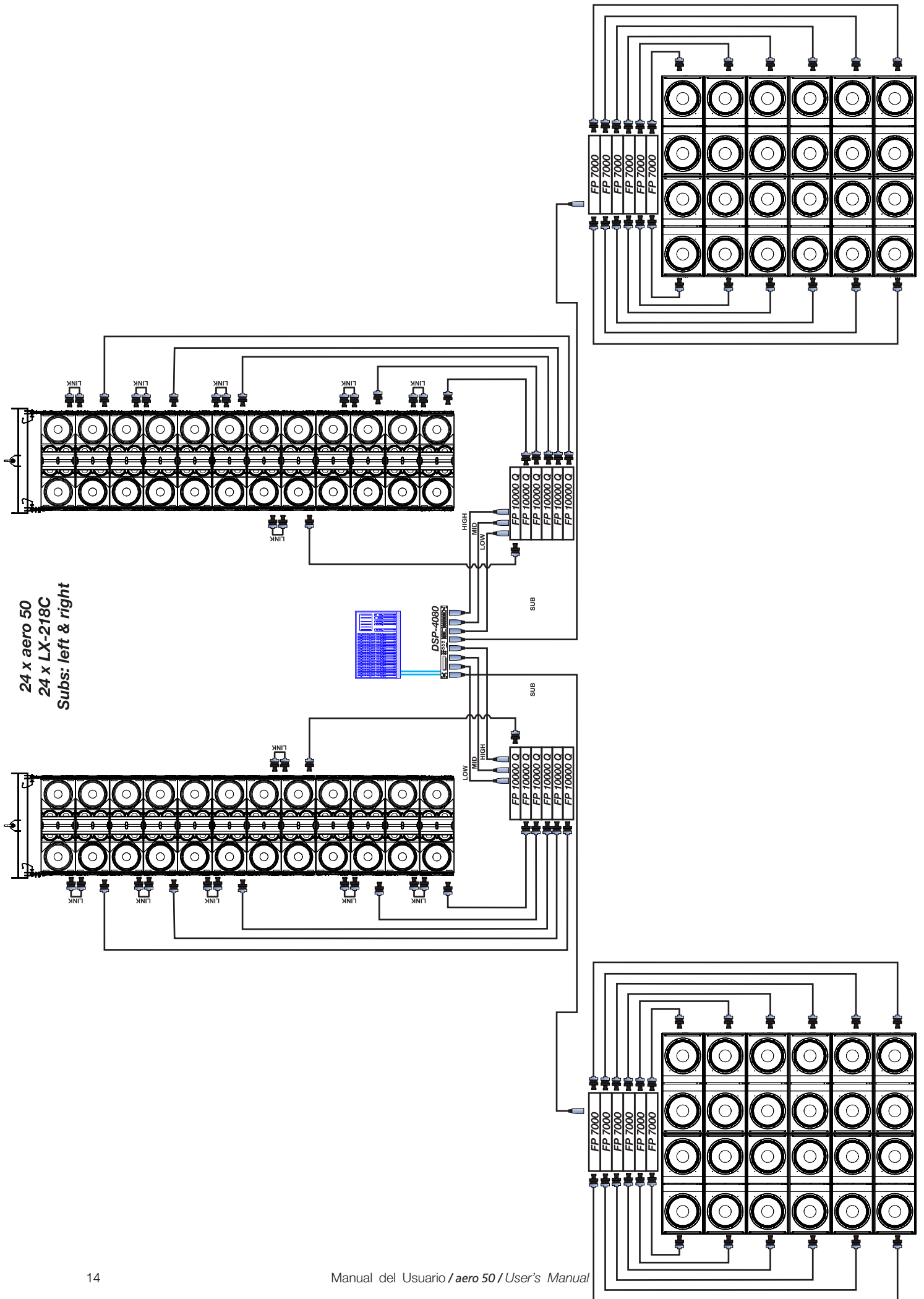

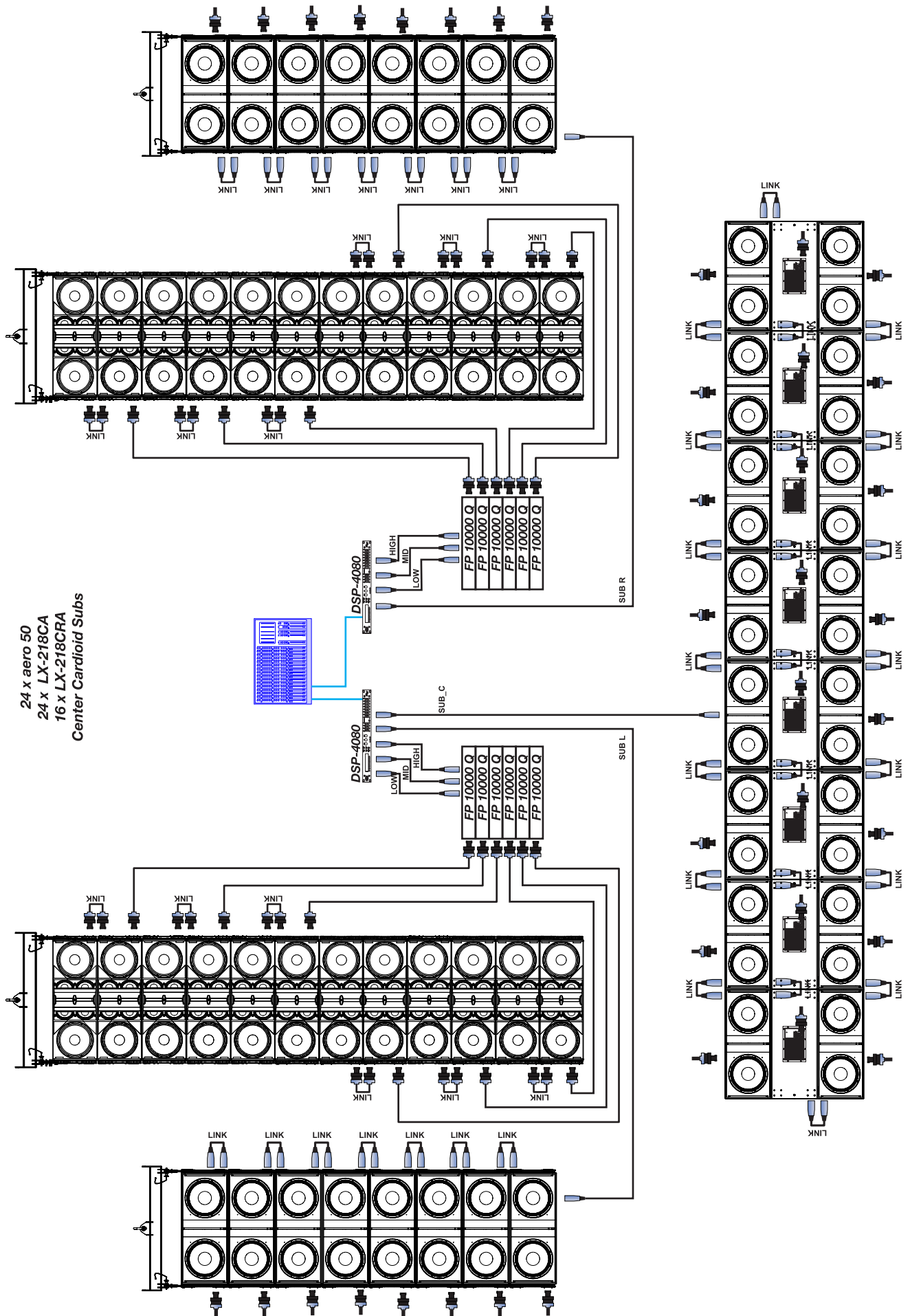

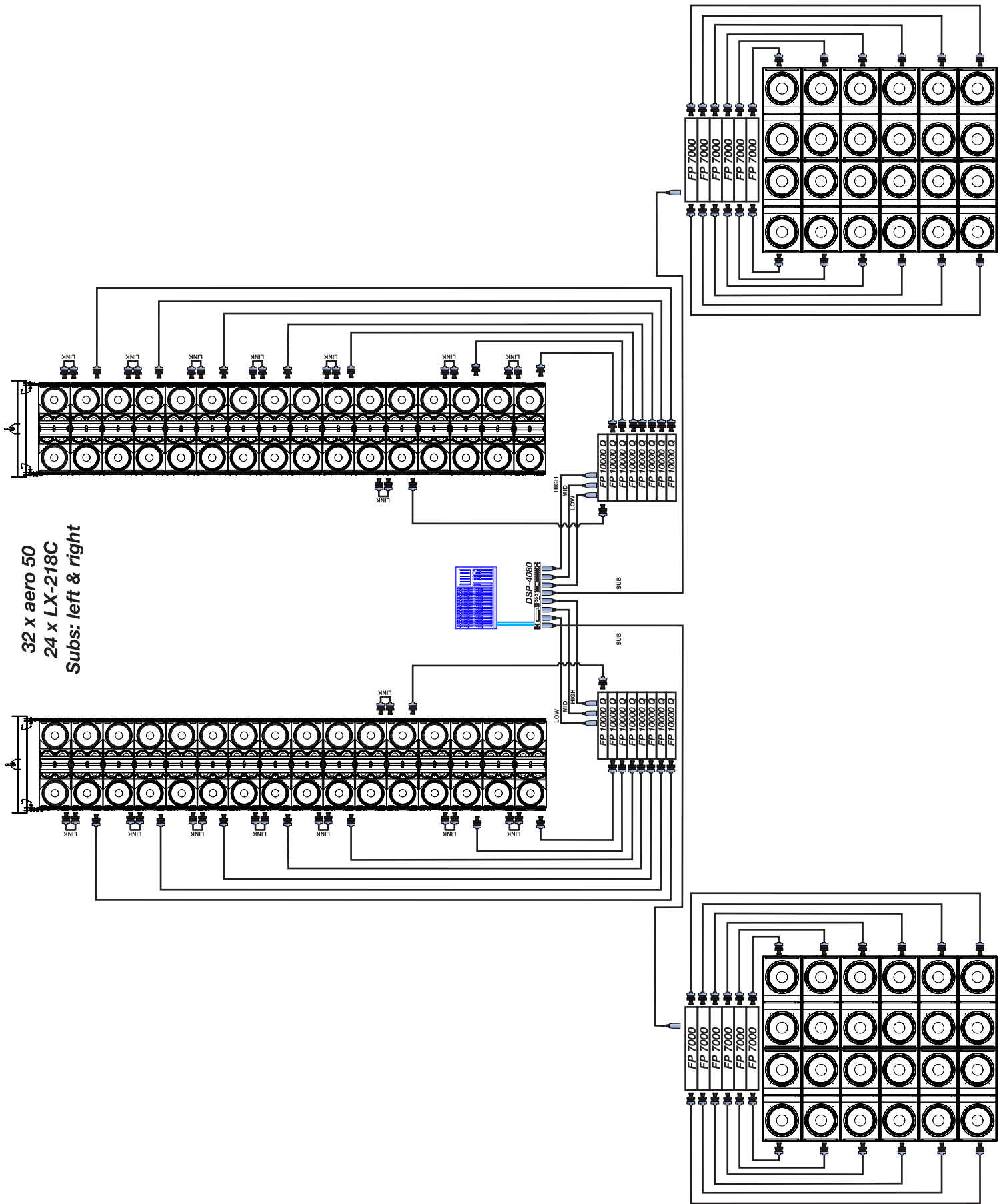

**SPECIFICATIONS**

Model	<b>aero 50</b>	<b>LX-218C</b>	<b>LX-218CR</b>
Frequency Range (-10 dB)	45 Hz – 20 kHz	28 Hz – 100 Hz	28 Hz – 100 Hz
Horizontal Coverage (-6dB)	90° Nominal	---	---
Vertical Coverage	Splay Angle Dependent	---	---
RMS (Average) Power Handling <sup>(1)</sup>	LF: 2 x 700 W, MF: 700W, HF: 300W	2000 W	2000 W
On-Axis Sensitivity 1 W / 1 m	LF: 99 dB SPL, MF: 104 dB SPL, HF: 112dB SPL	103 dB SPL	103 dB SPL
Rated Maximum Peak SPL at 1 m <sup>(2)</sup>	LF: 136 dB, MF: 139 dB, HF: 141 dB	142 dB	142 dB
Transducers/Replacement Parts	LF: 2 x 15GNR/GM 15G MF: 4 x 8MN/GM 8MN HF: 2 x M-75N/GM M-75N	2 18LX/GM 18LX	2 18LX/GM 18LX
Nominal Impedance	LF: 8+8ohms, MF: 8ohms, HF:16 ohms	4 ohms	4 ohms
Recommended Amplifier Power	4 amps 2 x 1400 @ 4 ohms ( 4 units aero 50)	2 x 2400 W @ 4 ohms ( 2 units LX-218C)	2 x 2400 W @ 4 ohms ( 2 units LX-218C)
Enclosure Geometry	Trapezoidal 5°	Rectangular	Rectangular
Enclosure Material	Birch Plywood	Birch Plywood	Birch Plywood
Color/Finish	Black Paint	Black Paint	Black Paint
Rigging System	Integrated in box design	---	Integrated in box design
Connectors	2 x NL8 wired as LF±1, LF±2, MF±3, HF±4	2 x NL8 wired ±1	2 x NL8 wired ±1
Dimensions (H x W x D)	47.5 x 135 x 62.7 cm (18.7 x 53.1 x 24.7 in)	55 x 128 x 63.2 cm (22 x 51 x 24.9 in)	55 x 135 x 69.6 cm (22 x 54 x 27.4 in)
Weight	85 kg (187 lbs)	78.5 kg (176.1 lbs)	94.5 kg (207.9 lbs)
Accessories	AX-aero50 Bumper Ax-Combo12 Rigging Adapter PL-50 Dolly Panel (included)	AX-aero50 Bumper Pick Up Bar for AX-aero50 Bumper AX-Combo12 Rigging Adapter KITW-100 Caster kit PL-LX218C Rigging hardware kit PL-LX218C Dolly Panel PL-218CS Flat Bed Dolly	AX-aero50 Bumper Pick Up Bar for AX-aero50 Bumper AX-Combo12 Rigging Adapter KITW-100 Caster kit PL-LX218C Dolly Panel (included) PL-218CS Flat Bed Dolly

(1).-Based on a 2 hour test continuously applying 6 dB crest factor pink noise (IEC shaped).

(2).-Maximum calculated Peak SPL based on sensitivity and RMS power handling.



[www.dasaudio.com](http://www.dasaudio.com)



**D.A.S. AUDIO, S.A.**

C/ Islas Baleares, 24  
46988 Fuente del Jarro  
Valencia, SPAIN  
Tel. 96 134 0525  
Tel. Intl. +34 96 134 0860  
Fax 96 134 0607  
Fax Intl. +34 96 134 0607

**D.A.S. AUDIO OF AMERICA, INC.**

Sunset Palmetto Park  
6816 NW 77th Court.  
Miami, FL. 33166 - U.S.A.  
TOLL FREE: 1-888DAS4USA  
Tel. +1 305 436 0521  
Fax +1 305 436 0528

**D.A.S. AUDIO ASIA PTE. LTD.**

25 Kaki Bukit Crescent #01-00/02-00  
Kaki Bukit Techpark 1  
Singapore 416256  
Tel. +65 6742 0151  
Fax +65 6742 0157