

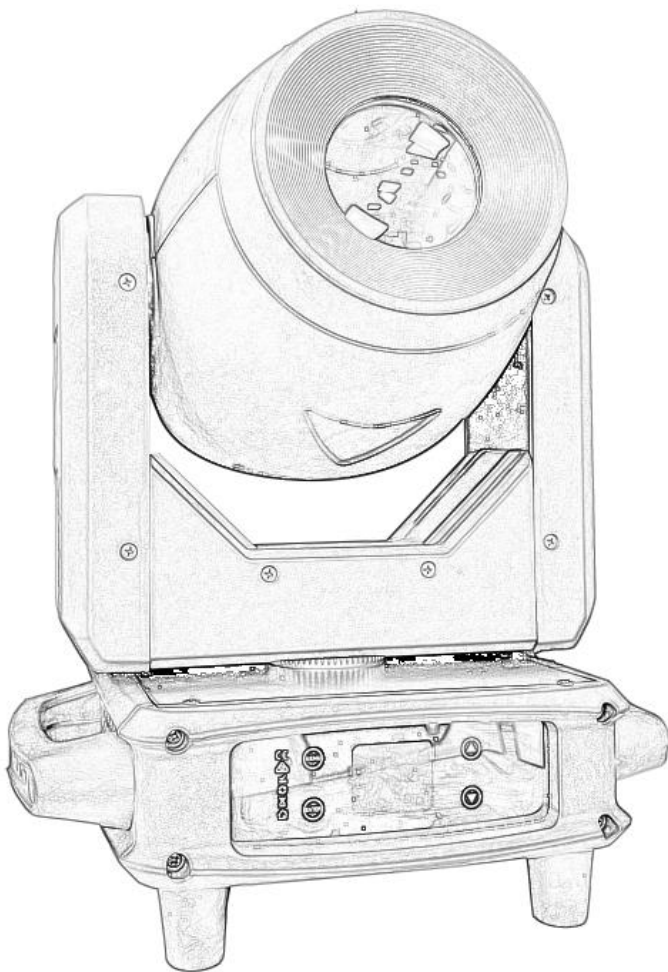

User manual



150 SPOT

Please read the instructions carefully before use

TABLE OF CONTENTS

1. Safety Instructions.....	3-4
2. Technical Specifications.....	4
3. Control Menu	5-7
4. DMX Channels	8-9
5. Dimension	10
6. LUX DATA	10
7. Trouble Shooting.....	11
8. Fixture Cleaning.....	11

STATEMENT

The product has well capability and intact packing when leave factory. All of the user should comply with warning item and manual, any misuse cause of the damages are not included in our guarantee, and also can not be responsible for any malfunction & problem owing to ignore the manual.

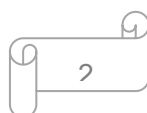

1. Safety Instructions

Please keep this User Guide for future consultation. If you sell the unit to another user, be sure that they also receive this instruction booklet.

- Unpack and check carefully there is no transportation damage before using the unit.
- Before operating, ensure that the voltage and frequency of power supply match the power requirements of the unit.
- It's important to ground the yellow/green conductor to earth in order to avoid electric shock.
- The unit is for indoor use only. Use only in a dry location.
- The unit must be installed in a location with adequate ventilation, at least 50cm from adjacent surfaces. Be sure that no ventilation slots are blocked.
- Disconnect main power before replacement or servicing.
- Make sure there are no flammable materials close to the unit while operating as it is fire hazard.
- Use safety cable when fixes this unit. DO NOT handle the unit by taking its head only, but always by taking its base.
- Maximum ambient temperature is T_a : 40°C. DO NOT operate it where the temperature is higher than this Unit surface temperature may reach up to 85°C. DO NOT touch the housing bare-hand during its operation. Turn off the power and allow about 15 minutes for the unit to cool down before replacing or serving.
- the event of serious operating problem, stop using the unit immediately. Never try to repair the unit by yourself. Repairs carried out by unskilled people can lead to damage or malfunction. Please contact the nearest authorized technical assistance center. Always use the same type spare parts.
- DO NOT touch any wire during operation as high voltage might be causing electric shock.

Warning:

- To prevent or reduce the risk of electrical shock or fire, do not expose the unit to rain or moisture.
- The housing, the lenses, or the ultraviolet filter must be replaced if they are visibly damaged.

Caution:

- There are no user serviceable parts inside the unit. DO NOT open the housing or attempt any repairs yourself. In the unlikely event your unit may require service, please contact your nearest dealer.

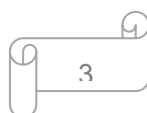

Installation:

- The unit should be mounted via its screw holes on the bracket. Always ensure that the unit is firmly fixed to avoid vibration and slipping while operating. And make sure that the structure to which you are attaching the unit is secure and is able to support a weight of 10 times of the unit's weight. Also always use a safety cable that can hold 12 times of the weight of the unit when installing the fixture.
- The equipment must be fixed by professionals. And it must be fixed at a place where is out of the touch of people.

2. Technical Specifications

Input Voltage: 100-240V, 50/60Hz

Output Voltage: V1:29V(Master board+LED driver), V2:12V(cooling fan+Display)

Power consumption: 180W

Power supply: 250W

Light source: 150W Osram LED Chip (24-27V,6A)

Color temperature: 8000K

Diameter of optic lens: 65mm

Beam angle: 15-17°

Color wheel: 1 color wheel, 7fixed colors plus white, two-way rainbow effect

Static gobo: 7 gobos plus 1 white circle

Rotation Gobo: 6 Gobo plus 1 white circle

Prism: 5 prism,can be rotated in both directions

Frost filter: with smooth wash effect

DMX Channel: 17CH

Operate mode: DMX512, self-propelled, master/slave,Sound active, RDM

Fixture size: 303*226*394mm

Net weight: 8.75 KG

Features:

1. Electric focusing system with 0-100% smooth dimming
2. Overheating self-energy protection can extending lamp life
- 3.Three phase Motor with SY Brand (XY axis magnetic coding positioning is more accurate)
4. With two angle lens 15° and 17° can change the gobo size
5. High quality LCD touch screen
6. Power in & Out connector,3 or 5pin XLR inout & output can optional
7. Folding clamp can optional

8. Housing material: PA6 Nylon(Solid,high temperature resistance up to 200°flame retardance)

3.Control Menu

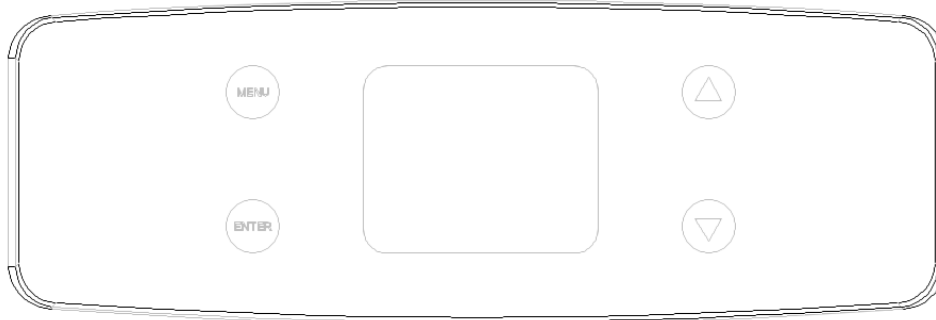

Up and down keys to select edit

Confirm key: execute function, start editing, exit editing

menu key: return to the previous interface

The following takes "Modify DMX Address Code" as an example to describe the use of buttons:

1. If it is not the main interface, press the menu key (one or more times) to return to the main interface
2. In the main interface, press the "Up" key or the "Down" key to select the "Settings" button
3. Press the "OK" button to enter the "Settings" interface
4. In the "Settings" interface, press the "Up" key or the "Down" key to select "DMX Address"
5. Press the "OK" key to enter the editing state
6. Press the "Up" key or "Down" key to modify the DMX address code
7. Press "OK" to exit the editing state

menu operation

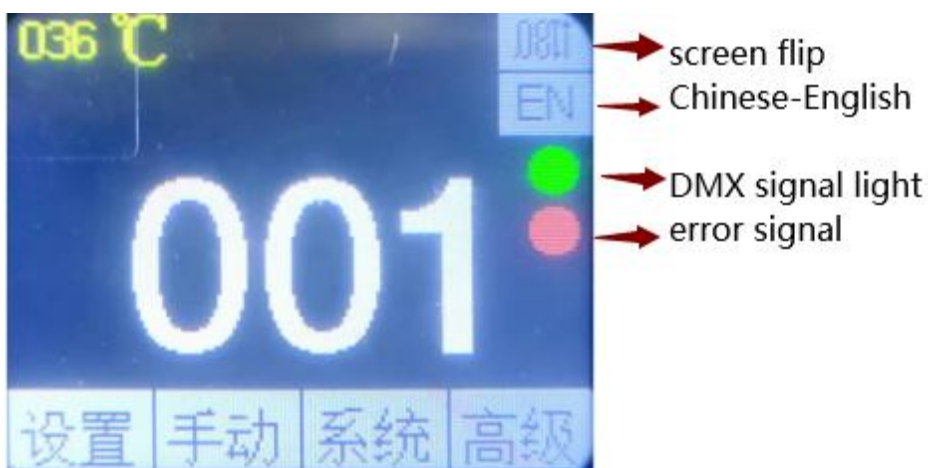

set up

Option	Description	
operating mode	DMX	Slave state: receive DMX signal from console or host
	AUTO	Master status: self-propelled and send DMX signal to slave
	voice control	
DMX address	1~512	Press the "OK" key to enter the editing state. At this time, the hundreds digit is selected, and the "up" and "down" keys are pressed to change the address code. Press the "OK" key again to select ten edits. Press the "OK" key again to select the one digit editing. Press again to exit the editing state
Motor reset	close	
	open	Lamp reset
channel mode	Standard 17CH	Standard 17-channel mode
X reverse	close	
	open	
Y reversal	close	
	open	
XY swap	close	
	open	Swap the channels of the XY axes (including fine-tuning)
XY encoder	open	Use the encoder (optical coupler) to judge the out-of-step and automatically correct the position
	close	Correct position without encoder (optocoupler)
DMX signal	Keep	Continue to operate as it is
	clear	The motor returns and stops running
restore default settings		Press the "OK" button to see the confirmation dialog box, press the "OK" button again to restore the default settings

MANU

Option	Description
1	X
2	X fine-tuning
3	Y
4	Y fine-tuning
5	XY velocity
6	Dimming
7	Strobe
8	color
9	pattern
10	glass pattern
11	glass pattern rotation
12	atomization
13	Prism
14	Prism rotation
15	focusing

16	enlarge
17	reset

Factory

Sensor detection	X Hall	
	Y Hall	
	color hall	
	Pattern Hall	
	glass pattern hall	
	Focus Hall	
	X-coded step value	
	Y-coded step value	
reset calibration	X axis	After entering the sub-interface, you can adjust the reset position of the X-axis, Y-axis and other motors to make up for the error in the hardware installation. The adjustment range is -128~+127, and +0 means no adjustment.
	Y axis	
	color	
	pattern	
	glass pattern	
	focusing	
	enlarge	
	Prism	
	frost	

System

Option	Description
DIS	Dashboard software version
MT	Motor board software version
system error	If the red ERR indicator is on, it means that the lamp is running incorrectly, and the details can be viewed from this sub-interface. After viewing, you can press the "Clear" button to clear the error record
total usage time	
This time of use	
temperature	Display the current temperature of the lamp bead

Common error messages	illustrate
MT board connection failed	The motor board is not responding. There is a problem with the serial communication line connecting the display board and the motor board, or there is a problem with the motor board.
X axis reset failed	There is a problem with the X-axis photoelectric switch, or the X-axis motor or motor board
Y axis reset failed	There is a problem with the Y-axis photoelectric switch, or the Y-axis motor or motor board
X axis Hall error	X-axis Hall, or there is a problem with the motor board
Y axis Hall error	Y-axis Hall, or there is a problem with the motor board
Color wheel reset failed	The color wheel Hall, or the color wheel motor has a problem
Pattern disk reset	Gobo Hall, or gobo motor is faulty

failed	
Focus reset failed	Focusing Hall, or there is a problem with the focusing motor

4.DMX Channels

CH17

CH	Function	CH Value	Effect
1	X	000-255	Horizontal 540 degree scan
2	X fine	000-255	Horizontal 1.2 degree fine-tuning
3	Y	000-255	Vertical 270 degree scan
4	Y fine	000-255	Vertical 1.2 degree fine-tuning
5	XY speed	000-255	Speed from fast to slow
6	Dimming	000-255	from dark to light
7	Strobe	000-003	Shutter open
		004-103	Strobe from slow to fast
		104-107	Shutter open
		108-207	Pulse strobe from slow to fast
		208-212	Shutter open
		213-251	Random strobe from slow to fast
		252-255	Shutter open
8	color	000 - 007	white light
		008 - 015	white light + color 1
		016 - 023	color 1
		024 - 031	color 1+color 2
		032 - 039	color 2
		040 - 047	color 2+color 3
		048 - 055	color 3
		056 - 063	color 3+color 4
		064 - 071	color 4
		072 - 079	color 4+color 5
		080 - 087	color 5
		088 - 095	color 5+color 6
		096 - 103	color 6
		104 - 111	color 6+color 7
		112 - 119	color 7
		120 - 127	Color 7+ White Light
	128 - 191	Reverse flow (from fast to slow)	
	192 - 255	Forward flow (from slow to fast)	
9	Static Gobo	000 - 007	Static Gobo1(white light)
		008 - 015	Static Gobo2
		016 - 023	Static Gobo3
		024 - 031	Static Gobo4
		032 - 039	Static Gobo5
		040 - 047	Static Gobo6
		048 - 055	Static Gobo7

		056 - 063 064 - 071 072 - 079 080 - 087 088 - 095 096 - 103 104 - 111 112 - 119 120 - 127 128 - 191 192 - 255	Static Gobo8 Static Gobo1shock (from slow to fast) Static Gobo2shock (from slow to fast) Static Gobo3shock (from slow to fast) Static Gobo4shock (from slow to fast) Static Gobo5shock (from slow to fast) Static Gobo6shock (from slow to fast) Static Gobo7shock (from slow to fast) Static Gobo8shock (from slow to fast) Forward flow (from fast to slow) Reverse flow (slow to fast)
10	Rotation Gobo	000 - 009 010 - 019 020 - 029 030 - 039 040 - 049 050 - 059 060 - 069 070 - 079 080 - 089 090 - 099 100 - 109 110 - 119 120 - 129 130 - 192 193 - 255	Rotation Gobo1 (white light) Rotation Gobo2 Rotation Gobo3 Rotation Gobo4 Rotation Gobo5 Rotation Gobo6 Rotation Gobo7 Static Gobo2shock (from slow to fast) Static Gobo3shock (from slow to fast) Static Gobo4shock (from slow to fast) Static Gobo5shock (from slow to fast) Static Gobo6shock (from slow to fast) Static Gobo7shock (from slow to fast) Forward flow (from fast to slow) Reverse flow (slow to fast)
11	Gobo Rotation	000-127 128-191 192-255	gobo angle adjustment gobo forward rotation gobo reverse rotation
12	frost	000-127 128-255	no effect frost cut in
13	Prism	000-127 128-255	Prism pops up Prism cut
14	Prism rotation	000-127 128-191 192-255	Prism angle adjustment Prism rotating forward flow Prism rotation reverse flow
15	focusing	000-255	gobo clarity from far to near
16	enlarge	000-127 128-255	no effect zoom in
17	reset	000-127 128-255	None, there is no action for the area without the specified function Reset all motors

5.Dimension

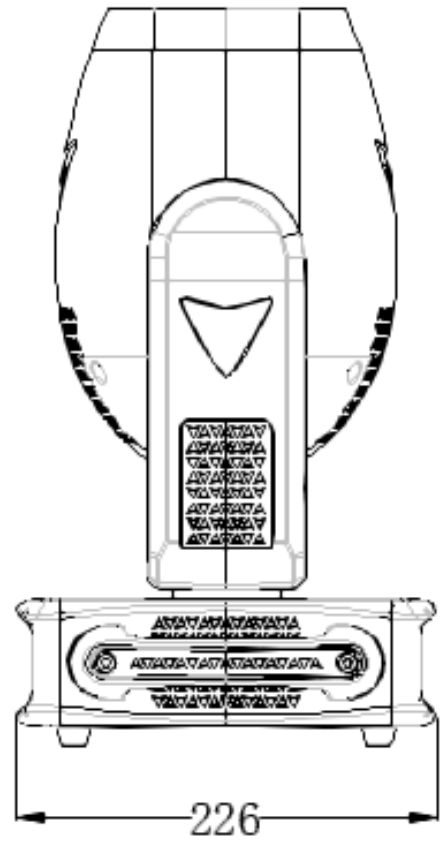
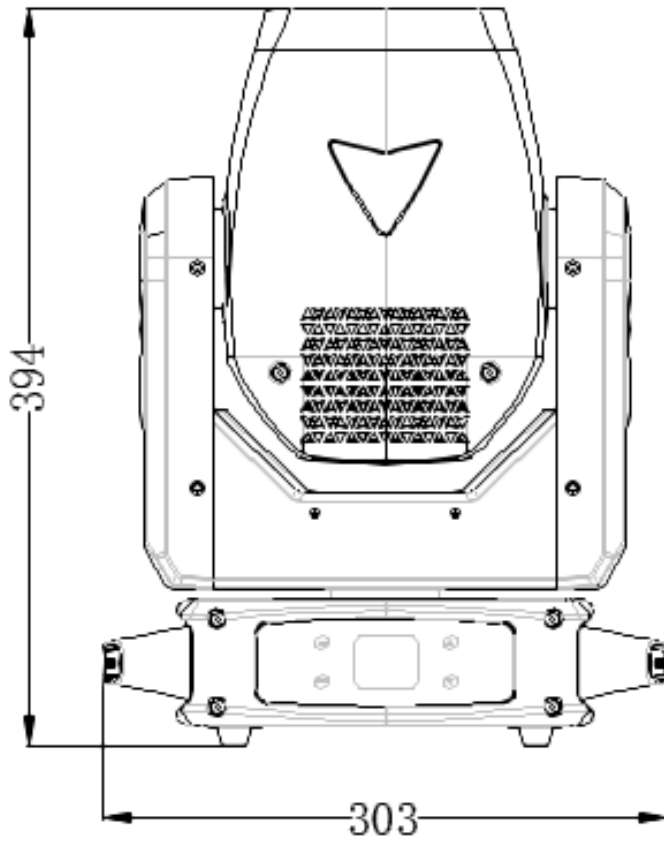

6.LUX DATA

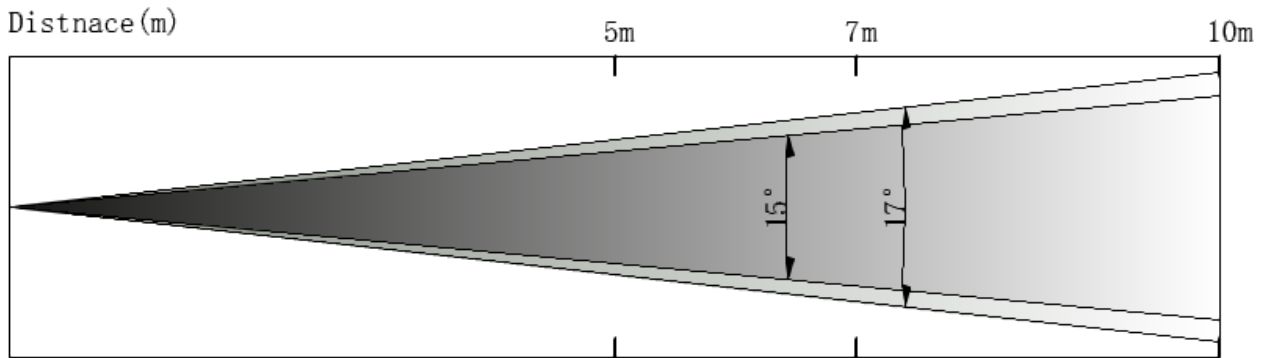

15° LUX	14500	7200	3800
Diameter (m)	0.94	1.57	1.85
17° LUX	9290	4820	2212
Diameter (m)	1.14	1.29	2.23

7. Trouble Shooting

Following are a few common problems that may occur during operation. Here are some suggestions for easy troubleshooting:

A. The unit does not work, no light and the fan does not work

1. Check the connection of power and main fuse.
2. Measure the mains voltage on the main connector.
3. Check the power on LED.

B. Not responding to DMX controller

1. DMX LED should be on. If not, check DMX connectors, cables to see if link properly.
2. If the DMX LED is on and no response to the channel, check the address settings and DMX polarity.
3. If you have intermittent DMX signal problems, check the pins on connectors or on PCB of the unit or the previous one.
4. Try to use another DMX controller.
5. Check if the DMX cables run near or run alongside to high voltage cables that may cause damage or interference to DMX interface circuit.

C. One of the channels is not working well

1. The stepper motor might be damaged or the cable connected to the PCB is broken.
2. The motor's drive IC on the PCB might be out of condition

8. Fixture Cleaning

The cleaning of internal and external optical lenses and/or mirrors must be carried out periodically to optimize light output. Cleaning frequency depends on the environment in which the fixture operates: damp, smoky or particularly dirty surrounding can cause greater accumulation of dirt on the unit's optics .

- Clean with soft cloth using normal glass cleaning fluid.
- Always dry the parts carefully.
- Clean the external optics at least every 20 days. Clean the internal optics at least every 30/60 days.