

# PHONIC

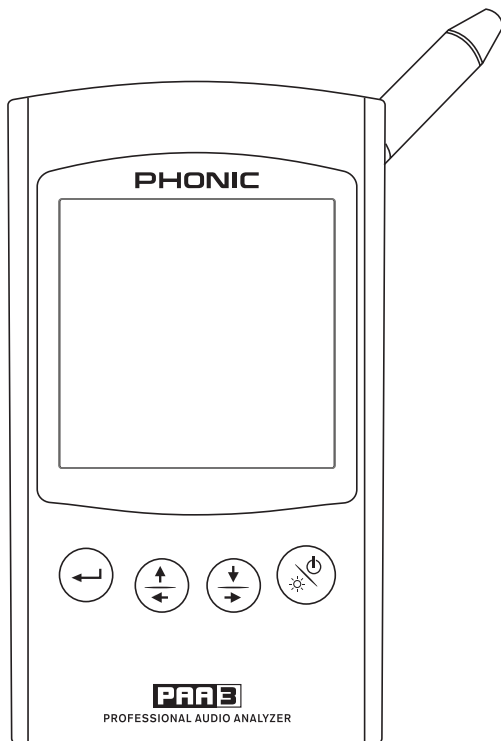

WWW.PHONIC.COM

## PAA3

- User's Manual
- Manual del Usuario
- 使用手册

# PAA3

Personal Audio Analyzer

Analizador Personal de Audio

个人音频分析仪

## CONTENTS

## CONTENIDO

## 目录

INTRODUCTION.....	4	INTRODUCCION.....	23	简介.....	43
FEATURES.....	4	CARACTERISTICAS.....	23	结构性能.....	43
CONTROLS AND DISPLAY.....	6	CONTROLES Y DISPLAY.....	25	控制和显示.....	45
GETTING STARTED.....	8	INICIANDO.....	27	准备工作.....	47
OPERATING TIPS.....	8	CONSEJOS DE OPERACION.....	28	操作方法.....	47
AUDIO ANALYSIS FUNCTIONS.....	9	FUNCIONES DE ANALISIS DE AUDIO.....	29	音频分析功能.....	48
RTA - Accoustic.....	9	RTA-Acústica.....	29	实时分析仪—声音.....	48
SPL Meter.....	9	Medidor de SPL.....	29	声压表.....	48
RT60.....	10	RT60.....	30	混响时间分析.....	49
RTA - Electrical Signal.....	11	RTA-Señal Eléctrica.....	31	实时分析仪—电信号.....	50
Level Meter.....	12	Medidor de Nivel.....	32	电平表.....	50
MEMORY.....	12	MEMORIA.....	32	记忆.....	51
Store.....	12	Almacenamiento.....	32	存储.....	51
Recall.....	13	Llamado.....	33	返回.....	51
Average.....	13	Promedio.....	33	平均值.....	51
EQ Setting.....	13	Ajustes de EQ.....	33	均衡设置.....	52
SETTINGS.....	14	CONFIGURACIONES.....	34	设置.....	52
Weighting.....	14	Ponderación.....	34	加权.....	52
Level Range.....	15	Rango de Nivel.....	34	电平范围.....	53
Max Level.....	15	Nivel Máximo.....	35	最大电平.....	53
Peak Hold.....	15	Peak Hold.....	35	峰值锁定.....	53
Response Time.....	15	Tiempo de Respuesta.....	35	响应时间.....	53
Calibration.....	15	Calibración.....	35	校准.....	53
PHASE CHECK.....	16	ANALIZADOR DE FASE.....	36	相位检查.....	54
GENERATOR.....	16	GENERADOR.....	36	测试信号发生器.....	54
POWER.....	17	ENERGÍA.....	37	电源.....	54
SIMULTANEOUS OPERATION WITH		OPERAION SIMULTANEA CON		连接电脑即时操作.....	55
DESKTOP.....	18	COMPUTADORA.....	38	规格.....	57
SPECIFICATIONS.....	20	ESPECIFICACIONES.....	40	测试信号音轨清单.....	58
AUDIO TEST SIGNAL TRACK		LISTA DE TRACKS DE SEÑALES DE		尺寸.....	59
LISTING.....	21	PRUEBA.....	41		
DIMENSIONS.....	59	DIMENSIONES.....	59		

Phonic preserves the right to improve or alter any information within this document without prior notice

Phonic se reserva el derecho de mejorar o alterar cualquier información provista dentro de este documento sin previo aviso

PHONIC保留不预先通知便可改变或更新本文件权利

V1.3 3/13/2017

## IMPORTANT SAFETY INSTRUCTIONS

The apparatus shall not be exposed to dripping or splashing and that no objects filled with liquids, such as vases, shall be placed on the apparatus. The MAINS plug is used as the disconnect device, the disconnect device shall remain readily operable.

**Warning:** the user shall not place this apparatus in the confined area during the operation so that the mains switch can be easily accessible.

1. Read these instructions before operating this apparatus.
2. Keep these instructions for future reference.
3. Heed all warnings to ensure safe operation.
4. Follow all instructions provided in this document.
5. Do not use this apparatus near water or in locations where condensation may occur.
6. Clean only with dry cloth. Do not use aerosol or liquid cleaners. Unplug this apparatus before cleaning.
7. Do not block any of the ventilation openings. Install in accordance with the manufacturer's instructions.
8. Do not install near any heat sources such as radiators, heat registers, stoves, or other apparatus (including amplifiers) that produce heat.
9. Do not defeat the safety purpose of the polarized or grounding-type plug. A polarized plug has two blades with one wider than the other. A grounding type plug has two blades and a third grounding prong. The wide blade or the third prong is provided for your safety. If the provided plug does not fit into your outlet, consult an electrician for replacement of the obsolete outlet.
10. Protect the power cord from being walked on or pinched particularly at plug, convenience receptacles, and the point where they exit from the apparatus.
11. Only use attachments/accessories specified by the manufacturer.
12. Use only with a cart, stand, tripod, bracket, or table specified by the manufacturer, or sold with the apparatus. When a cart is used, use caution when moving the cart/apparatus combination to avoid injury from tip-over.
13. Unplug this apparatus during lightning storms or when unused for long periods of time.
14. Refer all servicing to qualified service personnel. Servicing is required when the apparatus has been damaged in any way, such as power-supply cord or plug is damaged, liquid has been spilled or objects have fallen into the apparatus, the apparatus has been exposed to rain or moisture, does not operate normally, or has been dropped.

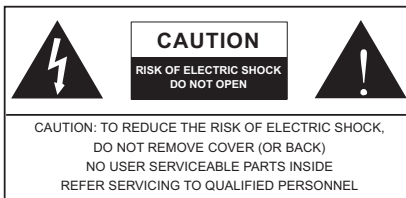

The lightning flash with arrowhead symbol, within an equilateral triangle, is intended to alert the user to the presence of uninsulated (dangerous voltage) within the product's enclosure that may be of sufficient magnitude to constitute a risk of electric shock to persons.



The exclamation point within an equilateral triangle is intended to alert the user to the presence of important operating and maintenance (servicing) instructions in the literature accompanying the appliance.

**WARNING:** To reduce the risk of fire or electric shock, do not expose this apparatus to rain or moisture.

**CAUTION:** Use of controls or adjustments or performance of procedures other than those specified may result in hazardous radiation exposure.



## INTRODUCTION

Thank you for purchasing the Phonic PAA3 Personal Audio Assistant, a highly accurate audio analyzer that sits comfortably in the palm of your hand, and features all the tools you need to set up any audio system.

With 31-band real-time spectrum analysis, Sound Pressure Level and dBu / dBV / line voltage measurement, EQ setting, phase checking, and reverb time analyzation, the PAA3 is the ideal companion for all sound engineers. This personal audio assistant is battery powered (4 AA size), with a built in microphone, and XLR inputs and outputs, ensuring all audio analyzing situations are possible. With the PAA3, you will conquer the accoustics of all environments with precision and ease.

Phonic understands the importance of sound reproduction management. We know that as a professional, your main concern is sound quality. Consequently, with an audio tool like the PAA3, you expect a precise ruler to obtain proper measurements and guarantee the best possible quality of sound that any professional would expect. Phonic, therefore, took the utmost of care in ensuring the PAA3 is an extremely accurate and effective means for you to gather all the useful data to determine what your set up needs.

To help you familiarize yourself with the PAA3, this manual includes instructions on every function listed in the main menu and sub-menus. It is recommended that you take the time to have a read of it, before you store it in an easily accessible place, in case it's needed in future.

## FEATURES

- Palm Sized Audio Analyzer
- 31-band Real Time Spectrum Analyzer
- Built-in calibrated measurement microphone
- Sound Pressure Level Meter from 30 dB to 130 dB
- Line signal measurement displayed in dBu, dBV, or Voltage
- A, C weighting or flat
- 3 level range selection for dB SPL and line signal
- Line signal measuring range:  
dBu = -50 ~ +40dBu  
dBV = -52 ~ +38dBV  
Volts = 5mV ~ +80V
- Maximum level and peak hold display
- 4 standard response times: 35 ms, 125 ms (F), 250 ms (M), 1 sec (S)
- 10 memories for measurement, and 6 for average calculation
- 31-band EQ setting level display (boost/cut)
- 160 x 160 graphic display with backlight and contrast adjustment
- Phase checker
- SPL meter Calibration through sound level calibrator (eg: B & K Type 4231)
- Reverb Time (RT60) Analyzer
- Noise generator with pink noise, 1 kHz and polarity test signal, balanced output
- USB communication port, for simultaneous operation through laptop or PC
- Low power consumption for up to 7 hours continuous operation with 4 AA size alkaline batteries (adapter power supply operation available. When power is used from adapter, it automatically cuts off battery power)
- 3 power modes: (1) Power saving mode: Auto Off- when none of the buttons has been pressed for 15 minutes (2) Manual Off (3) Off
- XLR input and output sockets

## INSIDE THE GIFT BOX

- 1 x PAA3 Unit
- 4 x AA Size Batteries
- 1 x AC Power Adaptor
- 1 x USB Cable
- 1 x Leather Case
- 1 x 3/8" and 5/8" Microphone Stand Adaptors
- 1 x CD-ROM including 26 test signals and software for PC interface
- 1 x User Manual (though if you didn't receive the user manual, you probably aren't reading this)



• 4 x AA Size Batteries

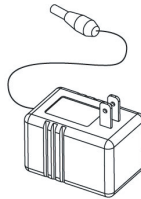

• Power Adaptor

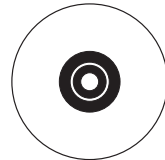

• CD-ROM

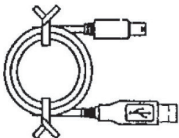

• USB Cable

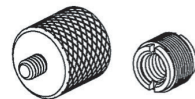

• Microphone Stand Adaptors

**CONTROLS AND DISPLAY**

1. **LCD Display**  
160 x 160 graphic LCD screen provides clear and large display.
2. **Power / Backlight Button**  
Before turning the power on, please ensure the POWER LOCK switch (at the rear of the PAA3) is set to the "ON" position. Pressing the Power button for 2 seconds will turn the power of the PAA3 on. After the power is on, this button allows users to turn the LCD backlight on and off. Holding the button for about 3 seconds will initiate the PAA3's shutdown sequence, saving all stored memories of the PAA3.
3. **Right / Down Button**  
Press this button to scroll down or to the right of the currently selected option.
4. **Left / Up Button**  
Press this button to scroll up or to the left of the currently selected option.
5. **Enter Button**  
Press this button to move from Real Time Spectrum Analyzer (RTA) display to the PAA3's function menu. After moving the cursor to a desired function in the menu by the right/down or left/up buttons, press the enter button to select.
6. **Jog Control**  
Jog control, on the left-hand side of this unit, provides users with a hassle free method of scrolling menus and selecting options with a single hand. Simply rotate to scroll up and down menus and push the wheel inwards to select (to either enter a sub menu or finalize a setting). Alternately, the three function buttons (the afore-mentioned buttons 3 to 5) may also be used to scroll options and finalize selections.
7. **5V DC Power Input**  
This port is used to connect the included 5V AC to DC converter. When adapter is plugged in, the battery power will be replaced by the adaptor, allowing users to use the PAA3 without fear of running out of power. Use the adapter provided along with the PAA3 only, as to avoid damaging the device.

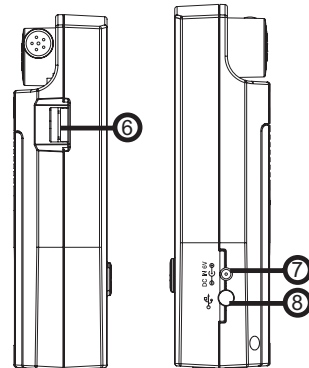
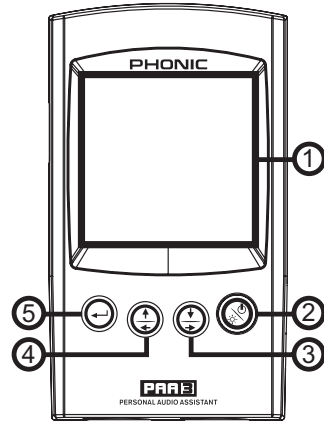

Please note that this will not charge batteries placed into the PAA3's battery compartment.

8. **USB Port**  
This USB connector is for the addition of the provided USB cable, to be connect the PAA3 to any desktop or notebook computer with a USB port. Please see the Simultaneous Operation With Desktop Computer section for more information.

**9. Male XLR Socket (Line Output)**

Through this XLR male connector, users can send out three built-in audio test signals: pink noise, 1 kHz tone, and the polarity signal. The output level is balanced -10dBu under a 6V DV power supply.

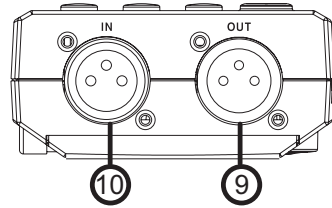

**10. Female XLR Socket (Line Input)**

This port allows you to send balanced, linelevel input to the PAA3. This signal input allows you to measure signals in dBu, dBV or AC voltage for balanced and unbalanced signals. It is particularly useful for checking the phase of a connections.

**11. Contrast Control**

By adjusting this control, users can change the contrast of the PAA3's LCD screen to better adapt the device to different lighting conditions.

**12. Power Lock**

Set this switch to the "ON" position before turning on the PAA3. You can set to the "OFF" position to prevent accidental powering up of the PAA3 when the unit is not in use. It is recommended that users move this switch to the off position when the PAA3 will not be used for a long period of time. Provided that the shut down procedure was followed correctly, turning this switch off after saving your settings will not cause the loss of any data.

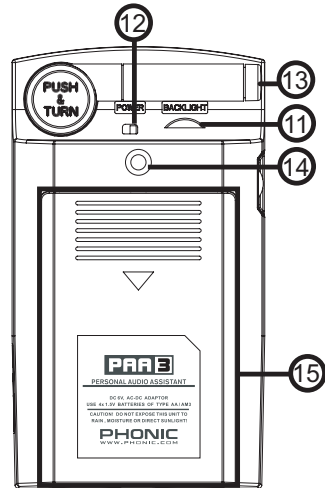

**13. Built-in Microphone**

Turn this accurate built-in Omni-directional mic to operation position (stands 45 degrees) by pressing the axis base. Always press the axis base before rotating the mic, as it is locked into place. If you attempt to rotate the mic without pushing in first, you could very well damage your PAA3.

**14. Stand Mount**

A stand mount is located on the back for connection to a tripod or any other stand that has a standard #6 - 20 connecting screw, often found on camera tripods. Also included is a stand adapter, allowing the PAA3 to be mounted on microphone stands as well.

**15. Battery Compartment**

The PAA3 requires four AA batteries for operation. Under normal conditions, the PAA3 can last for up to seven hours of continuous operation with the use of Duracell alkaline batteries.

## GETTING STARTED

1. Open the battery compartment and insert four AA batteries, ensuring the positive and negative ends are correctly aligned. You may simply opt to use the 6V DC power adaptor. To do so, plug the DC-head of the power adaptor to the PAA3, and the wallwart power connector into a suitable AC power source. **ATTENTION:** Use the adapter provided along with the PAA3 only, as to avoid damaging the PAA3. When connecting the adaptor, ensure the power of the PAA3 is off. Sudden unplugging of the adaptor power may cause the system to crash.
2. Push the axis base to release the PAA3's built in microphone. To best measure audio properties, turn the microphone until it sits at a suitable angle. The mic will lock into place at around 45 degrees.
3. Set the power switch (on the rear of the PAA3) to the "ON" position.
4. Press and hold the power button (on the front) for approximately three seconds to turn the power of the PAA3 on.
5. A startup screen will appear for about 10 seconds, then the real time spectrum analyzer will appear on the screen. Above the RTA, users will note the level range, weighting type, maximum sound pressure level, frequency range and SPL meter.
6. If a backlight is needed, simply press the power / backlight button. Press again to turn the backlight off.
7. Use the ENTER button to bring up the main PAA3 menu, then the UP / RIGHT and DOWN / LEFT buttons to navigate through the various options. Press the ENTER button to enter the main menu and use the UP / RIGHT and DOWN / LEFT buttons to select a function. Then press ENTER again to activate the highlight function or to enter into the submenus. The user may also use the jog control to activate all functions.

## OPERATING TIPS:

1. All functions can be activated by using the ENTER, LEFT / UP and DOWN / RIGHT buttons, or by the jog control. It is recommended to use these three buttons when taking low SPL measurements.
2. Pressing the ENTER button when the ESC (escape) is highlighted in most of the function menus will allow you to exit the main menu or sub-menus.
3. Press and hold the ENTER button or jog control for 2 seconds in most of the function menus to return to the real time spectrum analyzer.
4. When in RTA mode, holding the jog control or the ENTER button for 2 seconds will automatically jump to the Sound Pressure Level or Signal Level meters.
5. Always turn off the power by going to the POWER menu. Select OFF if you wish to save the measurement data and function setting into the memory of the PAA3. You may also simply hold the power / backlight button for 2.5 seconds.
6. It is not recommended to continue using PAA3 for any measurement when the battery is low. Always have extra batteries or the 6VDC power adaptor ready to ensure the accuracy of measurements.
7. When any result is above the level range, the measurement is still accurate unless a CLIPPING warning appears in the LEVEL box while taking the measurement. When clipping occurs, reset the level range.
8. To refresh the maximum SPL display, press both the left and right buttons simultaneously.
9. Turn on backlight only when the level range is set at 70~130 dB SPL or -20~+40 dBu. A noise will occur when turning on the backlight and it may affect the result of measurements in the lower range.
10. While taking measurements, hold the right button and press enter to immediately jump immediately to the STORE page.

When the battery is low, a blinking - and very aptly titled - "BATTERY LOW" icon will appear in the WEIGHT box, and remain on screen for the last 3 minutes of battery life. Low quality batteries may cause the PAA3 to shutdown without warning. An enlarged, blinking battery icon will appear in the center of the LCD screen if the user starts the PAA3 with insufficient battery power.

**Quick Shutdown:** Simply press the Power Button down for around 2.5 seconds and the shutdown procedure will be initiated automatically. This can save you valuable minutes while on the job!

## AUDIO ANALYSIS FUNCTIONS

The following section contains information concerning acoustic analysis, and illustrates how to use the PAA3 to measure various properties of your audio.

### RTA (Real Time Analyzer) - Accoustic

This function analyzes the audio received through either the built-in mic or Line In connection, divided into 31-bands at 1/3 octave intervals, and displays the relevant information on a bar graph that shows the decibel level of each band of sound from 20 Hz to 20 kHz in four different response times (35 ms, 125 ms, 250 ms, and 1 sec) and in three weighting types (A weighting, C weighting and Flat). For more info on response times and weighting, please consult the appropriate sections.

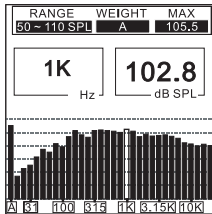

#### Procedure:

1. After the start up sequence of the PAA3 is complete, the real time analyzer will appear on the LCD screen.
2. Go to the SETTING menu to set the appropriate weighting, level range, response time, or other relevant properties.
3. Select VALUE from the main menu to enter RTA mode.
4. Press ENTER to freeze measurement data. Press ENTER again on the highlighted VALUE to view the value of each center frequency.
5. Use the LEFT/UP and RIGHT/ DOWN buttons or simply scroll the JOG control to view the level of dB SPL in real-time for the center frequency of all 31 bands. The default readout is the ALL FREQUENCY level. Beneath you will find two readouts: the numbers in the left column display the frequency while the numbers in the right column display the frequency levels. The graphic shown indicates that the user has set the level range at 50~110 SPL, A weighting. The max level during the time

of measurement is 105.5 dB, The user is reading at 1 kHz, which has a dB SPL of 102.8. If you would like to store the measurement data in the memory of PAA3, go to the STORE menu. Users can save the measured spectrum data into one of the ten memories. Please refer to MEMORY/ STORE for more information.

6. Scroll through the various values located in the 'Hz' box until you come to a flashing ESC. Press enter to exit RTA mode.

### SPL (Sound Pressure Level) Meter

This feature of the PAA3 gives users an accurate measurement of the overall "loudness" of their sound, measured in decibels (dB). This is a true RMS-measurement, using standard display time average, and standard A, C, and Flat weightings.

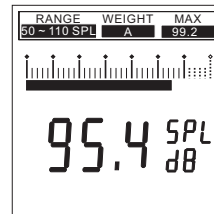

#### Procedure:

1. Enter the SPL/LINE menu and set the measurement unit to SPL.
  2. You may select a range level, weighting, response time or a maximum level by going into the SETTINGS menu, then onto the appropriate menus. The selected values of these options will be displayed above the RTA on the PAA3's default screen.
  3. On the main RTA display, hold the ENTER button for approximately 2 seconds to activate the SPL screen. Press the ENTER button once to exit.
- NB:** You can easily refresh the Max SPL value by holding both the ← left and → right keys simultaneously for at least one second.

### RT60 (Reverb Time Analyzing)

The RT60 function of the PAA3 is easy enough to understand: it is basically the time it takes for a signal to drop 60 dB. Getting the average of many different RT60 calculations from around a room allows users to get an idea as to how much absorption or reflection of audio the room provides. Depending on your needs, you may wish to have a high or low RT60 measurement. For example, for public speaking, an RT60 measurement of less than 1 second is preferable, as to have a clear, concise voice conveyed to the audience. With choirs or instrumental music, an RT60 measurement of greater than 1.5 seconds may be appropriate. It all depends on your needs.

#### Measuring Reverb Time:

1. Press enter to open the main menu and select "RT60."
2. Simply click "RUN" to get your RT60 reading.
3. The PAA3 will wait for a signal greater than 30 dB over the background noise level (detected prior to the measurement). A little helpful hint: the louder the test signal, the greater accuracy of your RT60 calculation.
4. Play the pink noise from the included CD through your audio system. Slowly move the master fader up, to a point where the audio level received by the PAA3 is greater than 30 dB. Quickly mute the system to get your RT60 reading as accurate as possible.
5. After the measurement is taken, the RT60 measurement will appear onscreen.

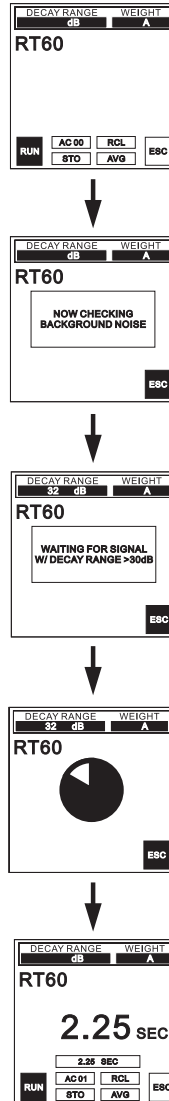

**Accumulation:** **AC 01**

Users are able to accumulate various RT60 calculations by pressing enter while the “ACxx” (where xx equals the number of accumulated values) option is highlighted. Up to 30 measurements can be accumulated. When RT60 measurements are accumulated, the average of said memories is automatically taken and displayed onscreen. After 30 memories have been accumulated, users will be forced to store their data, or else lose it.

**Store:** **STO**

Storing the results of RT60 measurements is simple. First highlight the STO option and push ENTER. When the store page comes up, choose one of the memory slots from 1 to 10, and select YES to store. The memory slot you selected will have a box surrounding the number now, as to indicate that a memory is stored in that particular slot. Selecting “A/C” will clear all memory slots.

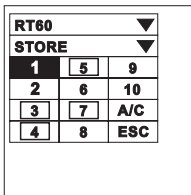

**Recall:** **RCL**

RT60 measurements can be recalled at anytime by selecting the “RCL” option in the RT60 menu. Memory slots 1 to 10 and A to F can all be recalled with ease. Each memory location page displays only 4 memories at a time, however, therefore users must select NEXT to continue onto the next page of stored memories.

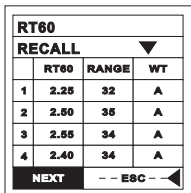

**Average:** **AVG**

To get the average of RT60 measurements that are stored in the PAA3, simply select AVG. Select from memories 1 to 10 (memory slots with saved data are indicated by a box surrounding the slot number), a dot will appear next to the number to show that a memory slot is selected. When all memories are selected, simply select AVG to determine the average, or ESC to escape. When differently weighted items are attempted to be averaged, a warning will appear onscreen advising users to select again.

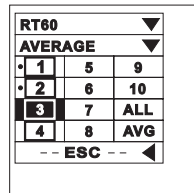

**RTA (Real Time Analyzer) - Electrical Signal**

By simply connecting an XLR jack to the PAA3's in jack, the RTA function can accurately measure your signal.

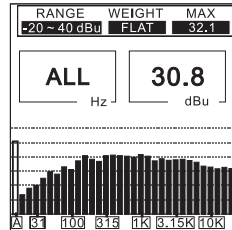

**Procedure:**

1. Enter the SPL/LINE menu and set the measurement unit to dBU, dBV, or voltage, as required.
2. Send a signal through the PAA3's female XLR jack (Pin 2 - Hot; Pin 3 - Cold; Pin 1 - Ground).
3. Go to the SETTING menu, where you may want to adjust the RANGE, WEIGHTING, RESP TIME (response time), or MAX LEVEL of your measurement.
4. Return to the RTA display. Here you can read the level of any or all frequencies. If all frequency readouts are needed, press “ENTER” button (or the jog control) for two seconds to enter line level meter.

## Level Meter

Measure the line voltage level in units of dBu, dBV, and AC voltage, using standard response time, and standard A, C, or flat weightings (under normal conditions, flat is preferable). Using the PAA3 to measure DC voltage may damage the PAA3 and will void the warranty.

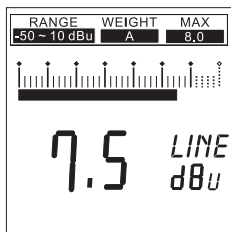

### Procedure:

1. Enter the SPL / LINE menu and set the measurement unit to dBu, dBV, or voltage, as required.
2. You may select a range level, weighting, response time or a maximum level by going into the SETTINGS menu, then onto the appropriate menus. The selected values of these options will be displayed above the RTA on the PAA3's default screen.
3. On the main RTA display, hold the ENTER button for approximately 2 seconds to activate the Level Meter screen. Press the ENTER button once to exit.

**NB.** You can easily refresh the Max SPL value by holding both the ← left and → right keys simultaneously for at least one second.

### ATTENTION:

If the level is lower than 127 mV when measuring voltage, the PAA3 will show it in mV. If the level is higher than 127mV, the data will be shown in voltage. For example, 120mV will read as 120.0mV, and 200mV will be shown as 0.2V.

The measurements for line voltage cannot be saved into the memory of the PAA3.

## MEMORY

The sub-menus of MEMORY include: STORE, RECALL, AVERAGE, EQ SETTING. Through these options, users are able to store their RTA measurements.

### Store

The user can save up to 10 sets of measured data (1 to 10), as well as 6 averaged sets (A to F), into the memory of the PAA3, allowing them to be used later for further analysis or uploading to your computer.

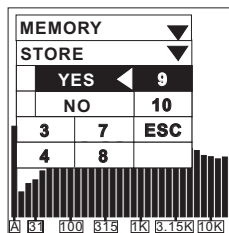

### Procedure (after making an acoustic RTA measurement):

1. To enter the store menu, hold the right button down and press ENTER, or go into the MEMORY menu and select STORE.
2. Select any slot, from position 1 to 10, and press YES to finalize. Previously saved data will be over-written.
3. Memory locations with stored data will be indicated with a box surrounding the slot number.
4. Selecting A/C in the STORE menu will automatically clear all memory slots.

**ATTENTION:** This function is only available when for acoustic analysis.

**Recall**

Users can recall all data saved in the memory of the PAA3 to read the measurements.

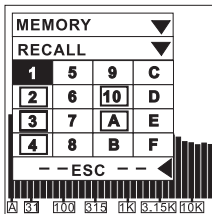

**Procedure:**

1. Enter into the MEMORY menu and select RECALL.
2. Select any of the used memory slots (indicated by a box surrounding the slot number) from 1 to 10 or A to F.
3. Each value will be displayed under VALUE in a 31-band center frequency value and an all frequency value.
4. When you see a flashing ESC in the Hz column, press ENTER to return to the MEMORY menu.

**Average**

The user can choose from memories 1 to 10 to compute average calculations, which are essential for EQ setting.

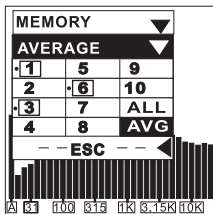

**Procedure:**

1. Go to the MEMORY menu and select AVERAGE.
2. Select any combination of data from memories 1 to 10 by moving the cursor to that number and pushing the ENTER key, or simply choose ALL if you want to do the average calculation for all ten saved measurements. Move the cursor over selected memories and press ENTER again to unselect.
3. A small dot will appear to the left of selected memory slots for identification.
4. Highlight AVG and press the ENTER key after all selections have been made. A list of selected measurements will be shown for confirmation.
5. Press RUN and the PAA3 will automatically calculate the average, or press ESC to cancel.

6. After running the average calculation, COMPLETE will appear on the screen. The user may then select from memory slots A to F (pressing YES to confirm) to save selected average calculations to the PAA3. Previously saved data will be automatically over-written. The PAA3 will automatically revert back to the EQ SETTING menu as soon as calculations are complete.

**ATTENTION:**

It is not recommended to calculate average of saved data with different weighting settings. The PAA3 will ignore the peak value when calculating the average, even if the peak value was activated.

**EQ Setting**

The EQ setting of audio system will vary from one venue to another. The ultimate goal in setting your EQ is to create a completely flat response and to eliminate every possible source of feedback. Though the PAA3's EQ SETTING function, even a novice user can successfully accomplish this.

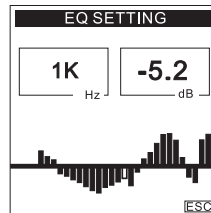

**Procedure:**

1. Play the pink noise from the included CD (or from the PAA3 GENERATOR tool) through your audio system.
2. Pick a number of significant locations around the area the audience will be situated, and take RTA measurements, and save each into the PAA3's memory.
3. Enter into the MEMORY / AVERAGE menu, and select the saved memories measured from those locations to calculate the average.
4. Go to the MEMORY / EQ SETTING menu. You will discover the amount of dB you need to boost or cut in each center frequency by using the Jog. Control or the UP/DOWN buttons to scroll. Example shown indicates that the user should cut -5.2 dB at 1 kHz.

**ATTENTION:**

Any user's EQ setting ability is limited by the temperature and the size of the audience at the time measurements were taken.

## SETTINGS

The sub-menus of SETTING include WEIGHTING, LEVEL RANGE, MAX LEVEL, PEAK HOLD, RESPONSE TIME, and CALIBRATION.

### Weighting

Any audio analyzer needs to be designed so that it hears sound properties in the same way as humans. Generally, the sensitivity of human hearing is restricted to the frequency range of 20 Hz to 20 kHz. The human ear, however, is most sensitive to sounds in the range of 500 Hz to 8 kHz. The ear becomes progressively less sensitive to sound out of this range.

To account for this limitation of human hearing, many audio analyzers, including the PAA3, incorporate a filtering of acoustic signals according to frequency. This filtering (weighting type) is devised to correspond to the varying sensitivity of the human ear to sound over the audible frequency range. The PAA3 comes with both A-weighting and C-weighting standardized by the ANSI (American National Standards Institute). A-weighting is the most frequently used weighting type and is used for measuring lower sound levels, while C-weighting is best suited for higher sound levels. The user can set the weighting for measurements in dBu, dBV or voltage.

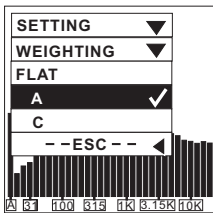

### Procedure:

1. Go to the SETTING/ WEIGHTING menu.
2. Select an appropriate weighting for the measurement. A tick appears next to your selection.
3. Press ESC to the previous menu.

### Level Range

The PAA3 has three different ranges for measurements in SPL, dBu, dBV and voltage.

<b>SPL:</b>	30~90	/	50~110	/	70~130
<b>dBu:</b>	-50~+10	/	-35~+25	/	-20~+40
<b>dBV:</b>	-52~+8	/	-37~+23	/	-22~+38
<b>VAC:</b>	5 m~2.45V	/	14m~14V	/	77.5m~8 0V

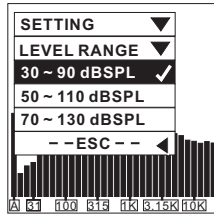

### Procedure:

1. Go to the SETTING menu, and proceed onto the LEVEL RANGE menu.
2. Select an appropriate level range for your measurement and press the ENTER button.
3. Press ESC to return to the previous menu, or hold the ENTER button for 2 seconds to revert back to the RTA screen.

**Max Level**

Maximum level your audio has reached will constantly be shown on the LCD screen. The user should reset the max level before each new measurement.

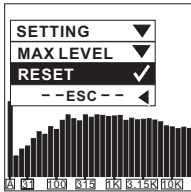

**Procedure:**

1. Enter the SETTING menu, then onto the MAX LEVEL menu.
2. Highlight RESET and press ENTER button to reset the max level measurement (doing so will automatically return you to the SETTING sub-menu). Press ESC to return if you do not want to reset.
3. A new max level display will be shown in the MAX column three seconds after returning to the RTA operation.  
Quick Refresh: While on the RTA screen, simply press the left and right buttons simultaneously to refresh the maximum level.

**Peak Hold**

Peak hold allows the user in RTA mode to constantly display the peak values of all measured frequencies, individually or collectively.

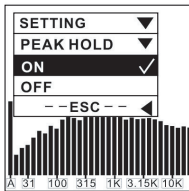

**Procedure:**

1. Enter the SETTING menu, then select the PEAK HOLD option.
2. Highlight and select ON to activate peak hold display.
3. Highlight and select OFF to cancel the peak hold display function.
4. Press ESC to return to the SETTING menu.

**ATTENTION:** When saving the memory with "PEAK HOLD" on, the peak level will only be displayed when the user recalls that memory when the PEAK HOLD setting is on. By setting the PEAK HOLD off, the user may then view the levels from all frequencies, individually or collectively.

**Response Time**

Response time settings will vary according to the user's measurement goals.

- 35 ms: Extremely Fast (for explosive sound)
- 125 ms (F): Fast
- 250 ms (M): Medium
- 1 sec (S): Slow

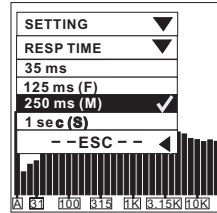

**Procedure:**

1. Go to the SETTING menu, then enter the RESP TIME menu.
2. Select an appropriate response time (a tick will appear next to your selection), or ESC to cancel.

**Calibration**

You should never actually need to calibrate your PAA3. If measurement data or operation of the unit is abnormal, however, it may be necessary. Anyone can calibrate the PAA3 and regain accurate sound pressure level measurement by using a sound level calibrator with 1/2" diameter adapter that sends out a 1 kHz tone. A B&K type 4231 sound level calibrator is suggested.

**Procedure:**

1. First, turn the PEAK HOLD OFF and set the RESP TIME (response time) to 250 ms.
2. Place a sound level calibrator with a microphone connector of a 1/2" diameter close to the PAA3's built-in mic.
3. Enter the SETTING menu and activate the function.
4. Adjust the level measured from the SPL calibrator by pressing UP/DOWN buttons until the level is equal to that of the sound level calibrator (typically 94 dB). Pressing the UP button each time will increase the value by 0.1dB; pressing the DOWN button each time will decrease by 0.1 dB.
5. Press the ENTER button to complete the calibration and to return to RTA display.

**ATTENTION:** If you want to cancel calibration, simply press the ENTER button to exit before making any adjustment. To resort the default calibration, simply adjust the offset value to 0.0 dB.

## PHASE CHECK

Measuring the phase of a signal allows you to figure out whether a speaker is correctly wired. A polarity signal is usually needed when checking the phase of a speaker or ensure that an output connection is correct.

### Procedure:

- Go to the SPL/LINE and select dBu to check a device's output connection or SPL to check a speaker's wiring.
- Go to the SETTING menu, and select POLARITY (or play the included PAA3 CD through your system).
- If checking speaker wiring, stand one meter in front of the speaker that plays the polarity signal, go to the PHASE CHECK menu and activate.
- A large "+" appearing on screen means the signal is in phase, and the wiring is correct.
- If instead of a "+" you get a "-", the speaker is out of phase and should be corrected.
- A big "?" or a screen switching between plus and minus symbols means the sound pressure level is at a level that is not detectable by the PAA3. So turn it up!

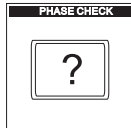
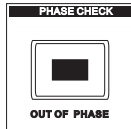
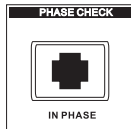

**ATTENTION:** Make sure the sound pressure level of the polarity signal from the system is louder than the environment noise, otherwise the PAA3 will not be able to detect the phase of the speaker.

## GENERATOR

The PAA3 can send out pink noise, a polarity signal, and a 1 kHz tone, all of which is sent out via the Male XLR connector (on the bottom of the PAA3) to any external system, at a level of -10 dBu.

### Tones:

**Pink noise:** mostly used for acoustic environment adjusting. For example: sound system equalization. **Polarity:** often used to check the phase of speakers.

**1 kHz tone:** a widely used among the professionals for audio signal testing.

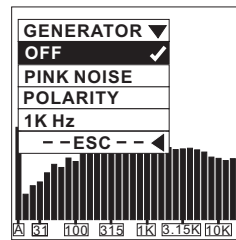

### Procedure:

- Connect the PAA3 to your audio system via the XLR-male connector on the bottom of the device.
- Go into the GENERATOR menu and select one of the signal to activate.
- Select ESC to return to previous menu or press OFF to cancel.

## POWER

To follow the correct power-down procedure is quite important to the PAA3. The easiest way to do so, however, is to hold the POWER / BACKLIGHT button of the PAA3 for approximately 2.5 seconds.

The device will automatically shutdown. If that's too easy, and you prefer to do things the difficult way, you may also do one of the following:

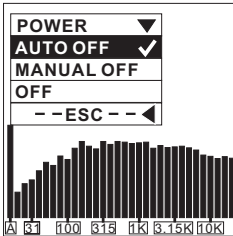

### Procedure:

1. Enter the POWER menu.
2. Select AUTO OFF, and the PAA3 will automatically shut itself down after being left idle for 15 minutes.
3. Selecting MANUAL OFF will disable AUTO OFF mode, and ensure the PAA3 will not shut itself down automatically, unless the batteries are low.
4. Select OFF, and the PAA3 will immediately shut down, saving all of your settings and measurement data before hand.

## SIMULTANEOUS OPERATION WITH DESKTOP

There are many advantages to being able to connect the PAA3 with your desktop computer or notebook. It allows remote operation of the PAA3, for one, which is particularly useful when taking measurements in areas that require an absence of any individuals. It also allows users to save and print data stored in the PAA3's memory.

The PAA3 software, supported by Windows 98 and above, can be found on the included CD (which, incidentally, also contains 26 testing signals). With this program, most functions are easily accessible through a menu identical to that of the PAA3 device itself.

**ATTENTION:** When operating the PAA3 through a PC, it is recommended that you make use of the power adapter instead of batteries. Also, choose an optimal position for the PAA3 to be placed before controlling the PAA3 with your computer.

### Installing the PAA3 software:

1. Turn on the computer and insert the PAA3 CD provided.
2. Find paa3\_setup.exe on the disc and double click to begin installation.
3. Select an appropriate installation directory and click "next" to continue. The PAA3 software will be installed automatically.

### PAA3 ON LINE

#### Connection:

1. After installation, open the PAA3 software.
2. Connect the PAA3 to your PC via the provided USB cable, then turn the PAA3 on.
3. Go to FILE, select ON LINE to connect to the PAA3. The data previously saved in the PAA3 will immediately be uploaded.
4. As soon as uploading is finished, you may begin to operate PAA3 by moving the cursor of the mouse and click the onscreen MENU to enter the various functions of the PAA3.
5. Now that PAA3 is operating simultaneously with the PC. The functions being activated will show both on the PAA3 and the PC or laptop.
6. Go to FILE and click ON LINE once more if you need to disable the PAA3's online operation.

#### Using the PAA3 on line:

The simple menu located below the FILE pull down menu at the top left hand side of main PAA3 program will allow users to access the PAA3's functions. This menu is basically identical to that of the PAA3 itself, so as long as you can navigate the PAA3 menu, you will be able to navigate this one.

#### Display Type:

Clicking on the SPL METER (or LEVEL METER) button to the right of the aforementioned menu will allow users to switch the on screen display type between that of the spectrum analysis and the meter display.

#### Memories:

Taking up most of the bottom half of the PAA3 program window is the memory section. Here lists all stored memories of the PAA3, downloaded to the computer. The two tabs allow users to view either the RTA memories or RT60 memories stored.

#### Backlight:

The backlight button to the right-hand-side of the PAA3 program will allow users to remotely active the PAA3's backlight.

**PAA3 OFF LINE**

The following functions can actually be accessed while in either on line or off line modes, unless indicated otherwise.

**Printing:**

1. Go to FILE, select Print, and a printer selection window will appear.
2. Select a printer from the list.
3. Select all data or one of the 16 memories. Users may also choose to print RT60 data.
4. Choose the print quality level (draft, low quality, medium quality, or high quality).
5. Click on Print, and the printer window will disappear as soon as the transmission is complete

**ATTENTION:** Along with the 31-band value of the selected memory and the EQ SETTING value, the name of the file, date of printing, LEVEL RANGE, WEIGHTING, and maximum level will also be printed on the data sheet.

**Open File:**

1. When off line, go to the FILE menu and select "Open File".
2. Locate the file previously saved in your PC and double click it.
3. The data is now ready for viewing, editing and any additions you may want to make to it.

**Save File:**

1. Go to the FILE menu and select Save File.
2. Select a directory (or create a new one), and give a name to the file.
3. Click on SAVE to save the file, and your entire session will be saved under that one file name.

**Peak Hold:**

1. Click on ON to view the peak value of each frequency and all frequency. The level can be found either from the bar meter or in the RTA peak chart on the right hand side of the program window.
2. Click on OFF to view the RTA value of each frequency and all frequency.

**MEMORY**

Select one of the memory slots (1 to 10 or A to F) in the RTA section of the memory chart at the bottom of the PAA3 software window to view the properties of saved data. Users can click on the bar-meter in the spectrum to see a specific frequency for readout or view them in the RTA Value column.

**ATTENTION:** User may rename every memory by double clicking the number of the memory in the memory chart.

**Memory Functions:**

The Memory pull down menu (as well as the following options) is not available while the PAA3 is under On Line operation.

**Average:**

1. Go to MEMORY / AVERAGE pull down menu, then select RTA AVERAGE or RT60 AVERAGE, to activate average function.
2. Choose by clicking memory 1 to 10 for average calculation. The original level range setting of each memory level range will display next to its number.
3. Click on AVG to run the calculation, the results of which will be displayed immediately.
4. Select a memory from A~F, and click on Save to save the result (the old one will be over-written), or click on Cancel to exit. User can view the result (either in graphic or in text) immediately both in result box or in the memory chart, with level range displayed at the top.

**EQ Setting:**

1. Select a memory (1 to 10 or A to F) with which you would like to adjust the EQ.
2. Go to MEMORY / EQ SETTING and activate EQ setting function.
3. Move the cursor and click on each bar meter to find out how much dB you need to cut or boost for each center frequency.

**Clear:**

1. Go to MEMORY, then onto CLEAR.
2. Select a memory slot, 1 to 10 or A to F, from the sub-menu, and the memory will be deleted immediately; select "All" if you need to wipe all memories saved.

**SPECIFICATIONS**

English

<b>Input/Output:</b>	
Microphone	Built-in miniature omni direction condenser microphone
Line	XLR jacks for line input and output
Data Port	USB 1.1 interface
<b>Display :</b>	
160X160 LCD screen with contrast adjustment and back light	
SPL, dBu, dBV, Voltage	Bar graph and digit display
RTA	31-band, 0.5dB resolution Center frequencies ISO standard from 20Hz to 20KHz
<b>Measurement Range</b>	
SPL (Microphone input)	30 to 130 dB SPL
dBu (Line input)	-50 to +40 dBu
dBV (Line Input)	-52 to +38 dBV
Voltage (Line Input)	5 mV to 80 V
<b>Setting</b>	
Weighting	A, C or Flat
Peak hold	ON/OFF
Maximum level display	RESET
Response time	35 ms, 125 ms, 250 ms, 1 sec
<b>Other Function</b>	
RT60	Reverberation time display, up to 30 seconds
Memory	10 RTA+ 6 average calculation
Average calculation	For 10 RTA memories
EQ setting value display	31-band
Phase checker	Through polarity signal
Transmission	Simultaneous operation with PC or laptop through USB port
<b>Noise Generator</b>	
<b>(Based on 5VDC power source)</b>	
Pink noise	Balanced output, -10 dBu
1K Hz Signal	Balanced output, -10 dBu
Polarity Signal	Balanced output, -10 dBu
<b>Power Source</b>	4 x AA batteries (battery life: up to 7 hours with alkaline batteries) or external 6 VDC adapter
<b>Dimensions (HxWxD)</b>	144.95 x 82.95 x 39.42 mm (5.7"x 3.26"x 1.55")
<b>Weight (with batteries)</b>	354 g (0.78 lbs)



## AUDIO TEST SIGNAL TRACK LISTING

The following is the list of the audio test signals on the CD included along with the PAA3:

- 1 Pink Noise, 60 seconds
- 2 Polarity Test Signal, 60 seconds
- 3 White Noise, 60 seconds
- 4 250 Hz Sine Wave, 30 seconds
- 5 500 Hz Sine Wave, 30 seconds
- 6 1 kHz Sine Wave, 30 seconds
- 7 2 kHz Sine Wave, 30 seconds
- 8 5 kHz Sine Wave, 30 seconds
- 9 10 kHz Sine Wave, 30 seconds
- 10 12.5 kHz Sine Wave, 30 seconds
- 11 Stepped Sequence Frequency Up 20Hz~20 kHz, 5 seconds for each frequency: 20Hz, 25Hz, 31.5Hz, 40Hz, 50Hz, 63Hz, 80Hz, 100Hz, 125Hz, 160Hz, 200Hz, 250Hz, 315Hz, 400Hz, 500Hz, 630Hz, 800Hz, 1 kHz, 1.25 kHz, 1.6 kHz, 2 kHz, 2.5 kHz, 3.15 kHz, 4 kHz, 5 kHz, 6.3 kHz, 8 kHz, 10 kHz, 12.5 kHz, 16 kHz, 20 kHz
- 12 Channel Test, at 1 kHz, Left Channel, 10 seconds
- 13 Channel Test, at 1 kHz, Right Channel, 10 seconds
- 14 Frequency Sweep Up 20Hz~20 kHz, 50 seconds
- 15 In Phase, at 250 Hz, 30 seconds
- 16 Out Of Phase, at 250 Hz, 30 seconds
- 17 Digital Blank, 60 seconds
- 18 SMPTE/EBU, Time Code, 30 seconds
- 19 High E
- 20 Low B
- 21 Low G
- 22 Low D
- 23 Low A
- 24 Low E
- 25 Frequency Sweep Up, 20Hz~20 kHz, 35 seconds
- 26 Frequency Sweep Down, 20 kHz~20Hz, 35 seconds

## INSTRUCCIONES DE SEGURIDAD

1. Lea estas instrucciones antes de operar este aparato.
2. Mantenga este instructivo para futuras referencias.
3. Preste atención a todas las advertencias para asegurar una operación adecuada.
4. Siga todas las instrucciones indicadas en este instructivo.
5. No utilice este aparato cerca del agua o en lugares donde se puedan dar condensaciones.

	<b>PRECAUCION</b> RIESGO DE SHOCK ELECTRICO NO ABRIR	
<b>PRECAUCION: PARA REDUCIR EL RIESGO DE SHOCK ELECTRICO NO REMUEVA LA TAPA (O LA CUBIERTA) NO HAY REFACCIONES DENTRO MANDE A SERVICIO CON EL PERSONAL CALIFICADO</b>		

6. Limpie solamente con lienzos secos. No utilice aerosol ni limpiadores líquidos. Desconecte este aparato antes de limpiarlo.
7. No bloquee ninguna de las aberturas de ventilación. Instale según las instrucciones del fabricante.
8. No lo instale cerca de cualquier fuente de calor como radiadores, registros de calor, estufas, u otro aparato (incluyendo amplificadores) que produzcan calor.



El símbolo con una flecha encerrado en un triángulo equilátero, es para alertar al usuario de la presencia de "voltaje peligroso" no aislado dentro del chasis del producto que pudiera ser de magnitud suficiente para constituir un riesgo de shock eléctrico a las personas.

9. No deshaga la opción de seguridad del plug polarizado o aterrizado. Una clavija polarizada tiene dos cuchillas una más grade que la otra. Una clavija del tipo polarizado tiene dos cuchillas y un diente. La cuchilla más ancha o el tercer diente esta incluido para su seguridad. Si esta clavija no se acomoda en su toma corriente, consulte un electricista para que cambie el toma corriente obsoleto.



El punto de exclamación dentro de un triángulo equilátero es para alertar al usuario de la presencia de instrucciones importantes de operación y mantenimiento (servicio) en la literatura que acompaña el equipo.

10. Proteja el cable de electricidad de ser pisado o picado particularmente en la clavija, los receptáculos y en el punto donde estos salgan del aparato. No pise los cables de alimentación de AC.

**ADVERTENCIA:** Para reducir el riesgo de shock o fuego eléctrico no exponga este aparato a la lluvia o a la humedad.

**PRECAUCION:** No use controles, ajustes, no realice procedimientos diferentes a los especificados, esto puede resultar en una peligrosa exposición a la radiación.

11. Utilice solamente accesorios o demás cosas especificadas por el fabricante.

12. Transporte solamente con un carro, pedestal, tripie abrazaderas o mesas espedicifadas por el fabricante, o incluidas con el aparato. Si se utiliza un carro, tenga precaución cuando mueva el carro con el aparato para evitar lesiones de cualquier tipo.



13. Desconecte este aparato durante tormentas eléctricas o cuando no se ocupe en periodos largos de tiempo.

14. Refiera todo el servicio al personal calificado. Se requiere de servicio cuando el aparato a sido dañado en cualquier manera, por ejemplo cuando el cable de alimentación de voltaje o la clavija han sido dañados, si se ha derramado liquido o si algun objeto a caído en el aparato, o si el aparato ha sido expuesto a la lluvia o a la humedad, no funcione normalmente o si ha sufrido una caída.

# PHONIC

DIMENSIONS DIMENSIONES 尺寸

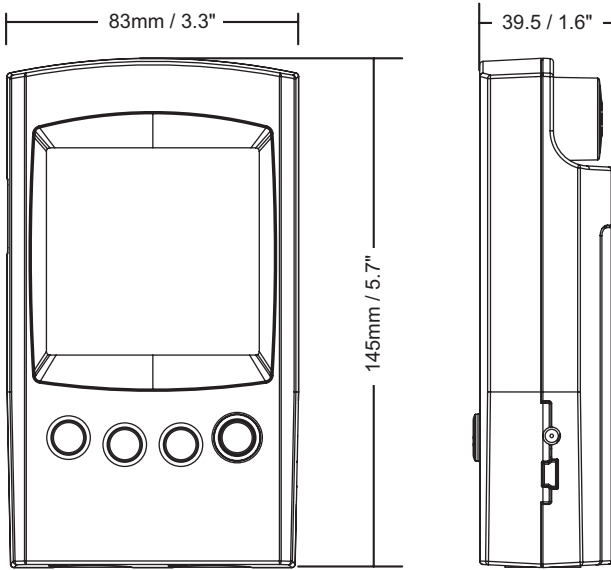

measurements are shown in mm/inches  
 Todas las medidas están mostradas en mm/pulgadas.  
 尺寸是以毫米mm/英寸inch表示。

## TO PURCHASE ADDITIONAL PHONIC GEAR AND ACCESSORIES

To purchase Phonic gear and optional accessories, contact any authorized Phonic distributor. For a list of Phonic distributors please visit our website at [www.phonic.com](http://www.phonic.com) and click on Get Gear. You may also contact Phonic directly and we will assist you in locating a distributor near you.

## SERVICE AND REPAIR

For replacement parts, service and repairs please contact the Phonic distributor in your country. Phonic does not release service manuals to consumers, and advice users to not attempt any self repairs, as doing so voids all warranties. You can locate a dealer near you at <http://www.phonic.com/where/>.

## WARRANTY INFORMATION

Phonic stands behind every product we make with a no-hassles warranty. Warranty coverage may be extended, depending on your region. Phonic Corporation warrants this product for a minimum of one year from the original date of purchase against defects in material and workmanship under use as instructed by the user's manual. Phonic, at its option, shall repair or replace the defective unit covered by this warranty. Please retain the dated sales receipt as evidence of the date of purchase. You will need it for any warranty service. No returns or repairs will be accepted without a proper RMA number (return merchandise authorization). In order to keep this warranty in effect, the product must have been handled and used as prescribed in the instructions accompanying this warranty. Any tempering of the product or attempts of self repair voids all warranty. This warranty does not cover any damage due to accident, misuse, abuse, or negligence. This warranty is valid only if the product was purchased new from an authorized Phonic dealer/distributor. For complete warranty policy information, please visit <http://www.phonic.com/warranty/>.

## CUSTOMER SERVICE AND TECHNICAL SUPPORT

We encourage you to visit our online help at <http://www.phonic.com/support/>. There you can find answers to frequently asked questions, tech tips, driver downloads, returns instruction and other helpful information.

## CÓMO COMPRAR EQUIPO ADICIONAL Y ACCESORIOS DE PHONIC

Para comprar equipos y accesorios opcionales de Phonic, póngase en contacto con cualquiera de los distribuidores autorizados de Phonic. Para una lista de los distribuidores de Phonic visite nuestra página web en [www.phonic.com](http://www.phonic.com) y entre a la sección Get Gear. También, puede ponerse en contacto directamente con Phonic y le ayudaremos a encontrar un distribuidor cerca de usted.

## SERVICIO Y REPARACIÓN

Para refacciones de reemplazo y reparaciones, por favor póngase en contacto con nuestro distribuidor de Phonic en su país. Phonic no distribuye manuales de servicio directamente a los consumidores y, avisa a los usuarios que no intenten hacer cualquier reparación por sí mismo, haciendo esto invalidará todas las garantías del equipo. Puede encontrar un distribuidor cerca de usted en <http://www.phonic.com/where/>.

## INFORMACIÓN DE LA GARANTÍA

Phonic respalda cada producto que hacemos con una garantía sin enredo. La cobertura de garantía podría ser ampliada dependiendo de su región. Phonic Corporation garantiza este producto por un mínimo de un año desde la fecha original de su compra, contra defectos en materiales y mano de obra bajo el uso que se instruya en el manual del usuario. Phonic, a su propia opinión, reparará o cambiará la unidad defectuosa que se encuentra dentro de esta garantía. Por favor, guarde los recibos de venta con la fecha de compra como evidencia de la fecha de compra. Va a necesitar este comprobante para cualquier servicio de garantía. No se aceptarán reparaciones o devoluciones sin un número RMA apropiado (return merchandise authorization). En orden de tener esta garantía válida, el producto deberá de haber sido manejado y utilizado como se describe en las instrucciones que acompañan esta garantía. Cualquier atentado hacia el producto o cualquier intento de repararlo por usted mismo, cancelará completamente esta garantía. Esta garantía no cubre daños ocasionados por accidentes, mal uso, abuso o negligencia. Esta garantía es válida solamente si el producto fue comprado nuevo de un representante/distribuidor autorizado de Phonic. Para la información completa acerca de la política de garantía, por favor visite <http://www.phonic.com/warranty/>.

## SERVICIO AL CLIENTE Y SOPORTE TÉCNICO

Le invitamos a que visite nuestro sistema de ayuda en línea en [www.phonic.com/support/](http://www.phonic.com/support/). Ahí podrá encontrar respuestas a las preguntas más frecuentes, consejos técnicos, descarga de drivers, instrucciones de devolución de equipos y más información de mucho interés.

## 购买Phonic产品及其周边器材

使用者如需购买Phonic产品及其周边器材, 请与Phonic授权的经销商取得联系。访问我们的网站 [www.phonic.com](http://www.phonic.com), 点击 Get Gear 即可查询Phonic地区经销商的联系方式。您也可直接联系Phonic公司, 我们将协助您快速定位离您最近的经销商。

## 服务与维修

订购替换零件或维修事宜, 请与您所在地区的Phonic经销商联系。Phonic不对使用者发行维修手册, 且建议使用者切勿擅自维修机器, 否则将无法获得任何保固服务。您可登录 <http://www.phonic.com/where/> 定位离您最近的经销商。

## 产品保固资讯

Phonic承诺对每项产品提供最完善的保固服务。我们将根据客户群体所在的地区来拓展我们的服务所涵盖的范围。自原始购买日起, Phonic即对在严格遵照使用说明的操作规范下, 因产品材质和做工所产生的问题提供至少1年的保固服务。Phonic可在此保固范围内任意地选择维修或更换缺陷产品。请务必妥善保管购买产品的凭证, 以此获得保固服务。未获得RMA号的将不予受理退货, 以及保固服务。保固服务只限于正常使用情况下产生的问题。使用者需严格遵照使用说明正确使用, 任何肆意损坏或擅自维修机器, 意外事故, 错误使用, 人为疏忽, 都将不在保固受理范围内。此外, 担保维修只限于在授权经销商处的有效购买。欲知全部的保固政策资讯, 请参访 <http://www.phonic.com/warranty/>。

## 客户服务和技术支持

欢迎您访问我们的网站 <http://www.phonic.com/support/>。从该网站上, 您可获得各种常见问题的答案, 技术指导, 并可下载产品驱动, 获得有关退货指导以及其它帮助资讯。

# PHONIC

support@phonic.com <http://www.phonic.com>